



DYNACOMP

The top-class dynamic response compensator

Reactive power and Power Quality

Reactive power

Excessive reactive power drawn by linear- and non-linear loads deteriorates the Power Quality of the network in a variety of ways. This leads to reduced running efficiency and production quality of plants and an increased running cost.

High reactive power demand by the load results in a low displacement power factor ($\cos \varphi$). This may lead to financial losses due to penalties imposed by the supply utility. In addition, the resulting higher current creates additional losses in the supply network making it operate less efficiently and also shortens the lifetime of the network components (e.g. cables, transformers, etc.) due to the increased electrical and thermal stress.

High reactive power flow results in an unstable bus voltage, which may have severe effects on productivity. When the reactive power demand is fluctuating due to fluctuating loads, this may lead to flicker which is potentially harmful to the human health.

Traditionally, low $\cos \varphi$ problems are solved using fixed or contactor switched capacitor banks. However, loads whose reactive power demand is high and/or has a rapidly changing pattern, cannot be adequately compensated by these solutions. Examples of such loads include thyristor converters used in harbour cranes, rubber mixers, extrusion lines, compressors, offshore drilling applications etc, welding loads used in the automobile industry etc. and motors of large capacity which draw a very high starting current

Some of the main problems created by these loads are:

- Low $\cos \varphi$ resulting in penalties and network overload
- Voltage sags and undervoltage resulting in production halt
- High harmonic levels generated by non-linear loads
- Voltage drop compensation

The ABB Dynacomp which uses fast static switches and advanced microprocessor based technology is best suited to compensate such loads and take care of the above-mentioned problems. The transient free switching, which is not possible with contactor switched capacitor banks, incorporated in each Dynacomp ensures smooth and reliable operation for even the most sensitive networks. A properly selected detuning reactor also helps in harmonic absorption, thereby reducing the voltage distortion.

Voltage drop compensation

Voltage variations are mainly caused by fast varying load which draws high reactive power from the supply network and thereby causes voltage drop across the network impedance as given next:

where:
$$\Delta V_1 = R_{network} \cdot I_p + X_{network} \cdot I_q$$

- ΔV_1 is the real part of the voltage drop at the PCC
- I_p and I_q are the active and the reactive contributions of the load current
- $R_{network}$ is the resistive part of the network impedance
- $X_{network}$ is the reactive part of the network impedance

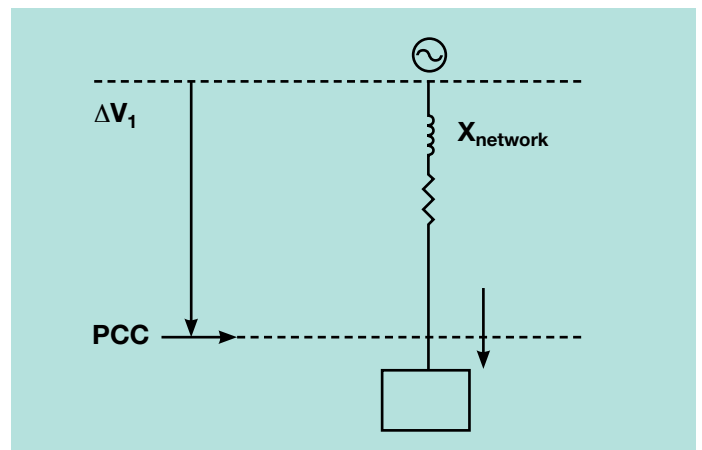

In a “strong” network, the resistive part is generally small and the corresponding voltage drop is negligible. However, in a “weak” network where line resistance is significant, even the active part of the current may result in significant voltage drop.

The voltage drop ΔV_1 can be compensated by a dynamic compensator connected in parallel to the load providing the following capacitive current :

where:
$$I_{compensator} = I_q + \frac{I}{Q_{network}} \cdot I_p$$

- $I_{compensator}$ is the current injected by the compensator
- I_p and I_q are the active and the reactive contributions of the load current
- $Q_{network}$ is the quality factor of the supply network
($= X_{network}/R_{network}$)

A normal compensator cannot control flicker efficiently as it is designed to compensate only the reactive part of the load current. ABB’s advanced controller RVT-D has a special feature to compensate even for the voltage drop due to the line resistance and active part of the current. The Dynacomp controller type RVT-D allows the user to set the desired X/R value in order to compensate fully the voltage drop ΔV_1 under all operating conditions.

Principle and advantages

Dynacomp principle

The Dynacomp is a circuit consisting of capacitors and reactors switched on the network by solid state power electronics, without any moving part. A three-phase Dynacomp circuit is represented below. Single-phase Dynacomps are also available. The Dynacomp can compensate low voltage equipment for nominal voltages from 380V up to 690V.

The thyristors are fired at the natural zero crossing of the capacitive current. As a result, capacitors are connected to the network without transients.

The control is such that only complete cycles of the current are allowed. This ensures that no harmonics or transients are generated by the Dynacomp.

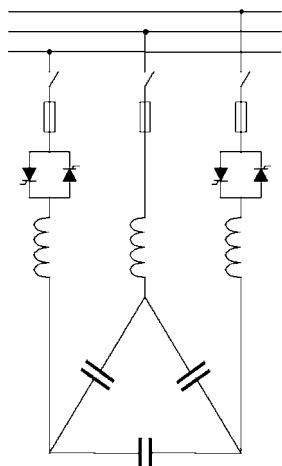

Advantages of the Dynacomp

- Ultra-rapid power factor compensation
- Reduction of voltage drops
- Transient free switching
- Very high number of switching operations
- Modular and compact standardized design
- Easy to install and extend
- Advanced communication features with Modbus
- Power steps from 100 to 400 kvar
- Up to 32 power steps with CAN control bus
- Harmonics absorption
- ABB micro-processor based RVT-D controller
- Network measurements, including harmonics
- Direct connection up to 690V
- ABB large field experience
- ISO 9001 certification
- ISO 14001 certification

Connection diagram

- This connection is valid for closed-loop and/or external trigger control systems. For other configurations, please consult us. Measurements provided by the controller are network measurements in any case.
- Single-phase systems are also available. Please consult us.
- External trigger system, if needed, is made through one or two inputs (opto1 and opto2: 15-24Vdc).

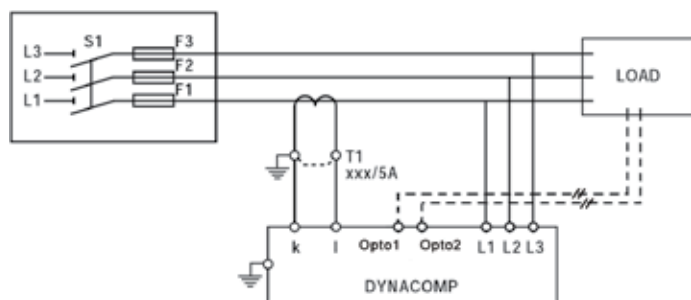

Three-phase system

Dynacomp vs electromechanical switching of capacitors

Electromechanical switching of capacitors

Transients at switching

Conventional banks with contactors are switched on when reactive power is needed, but the precise instant of switching is not controlled. This has the consequence that the switching of the capacitors results in a big transient. This transient disturbs the electrical network, is dangerous for the contactors and increases the stress on the capacitors. The disturbance created in the voltage waveform could affect sensitive equipment. This is shown in the figure below, where an 80 kvar step is switched on by contactors. The current reaches 3640 A peak which is approximately twelve times the nominal 304 A peak.

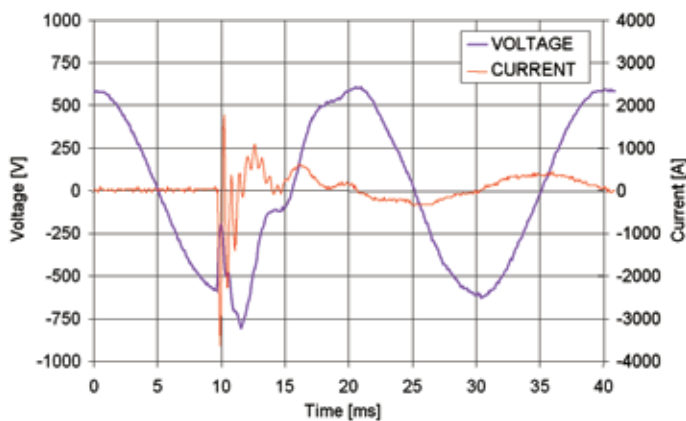

Current waveform when switching a conventional bank with contactors (transient)

Slow response time

Electromechanically switched power factor correction systems are fitted with discharge resistors. This allows reducing the voltage difference between the capacitors and the network and consequently the magnitude of the transients. Discharging the capacitors takes tens of seconds and tremendously limits the response time of such system, without suppressing the transients.

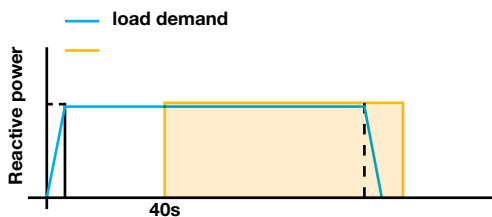

Limited life

Contactors have a limited lifetime and need to be replaced regularly. Such systems also require important maintenance efforts.

The Dynacomp: the top-class dynamic compensator

Transient free switching

The Dynacomp, fitted with static switches instead of contactors, is the perfect choice in applications where transient-free switching is required. It will not cause disturbances to sensitive networks or neighbouring equipment. The figure below shows the switching of an 80 kvar step using the static switch of the Dynacomp. The current reaches only 304 A peak, i.e. the nominal value.

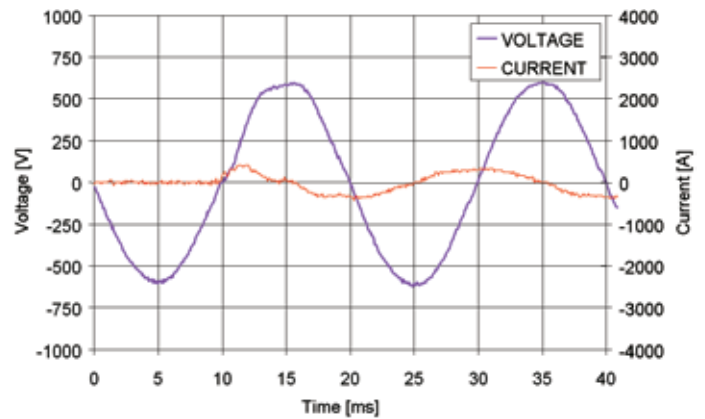

Current waveform when switching a Dynacomp (no transient)

Fast response time

The powerful control of the Dynacomp and its switching concept allows dynamic response times less than two network periods for power factor correction, less than one network period for voltage drop compensation and virtually instantaneous if an external signal is available.

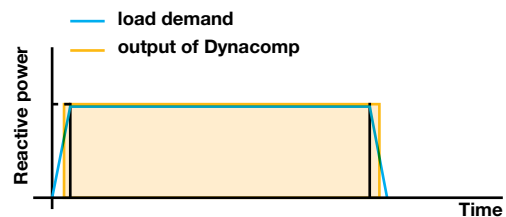

Long life

The transient free switching (with no electric arc, no moving parts) combined with the self healing capacitors used in the Dynacomp guarantees a very long life time of the system without any limitation in the number of switching operations.

Description

The Dynacomp consists of capacitors, reactors, Dynaswitches and the electronic control system. These components are mounted in a cubicle together with auxiliary apparatus to form a factory assembled and tested system.

The Dynacomp is a standard product, designed to suit all possible requirements of a fast varying load. Wide network voltage range, flexible power range, modular design, choice of detuning reactors etc. are some of the features which make the Dynacomp the ideal solution for all applications needing a fast and smooth switching of reactive power.

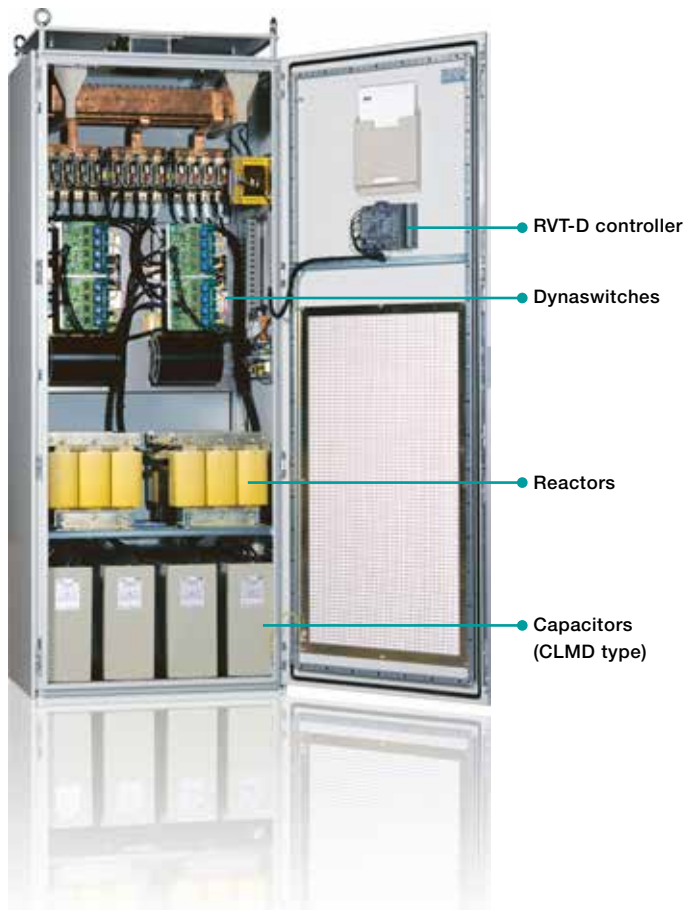

RVT-D controller

Micro-processor based, the RVT-D is designed to meet the specific needs of the customer :

- for accurate and fast power factor compensation.
- for minimum response time allowing mitigation of voltage drops and flicker effects.

The RVT-D has features including:

- full graphics display with backlighting.
- network measurements: voltage, current, THDV, THDI, harmonics spectrum, Dynacomp current, powers and more.
- programmable protection thresholds (undervoltage, overvoltage, overtemperature, excessive harmonic distortion and power outage).

- a help button giving instant access to a description of all RVT-D's features and functionality.
- a printer connection.
- Modbus communication.

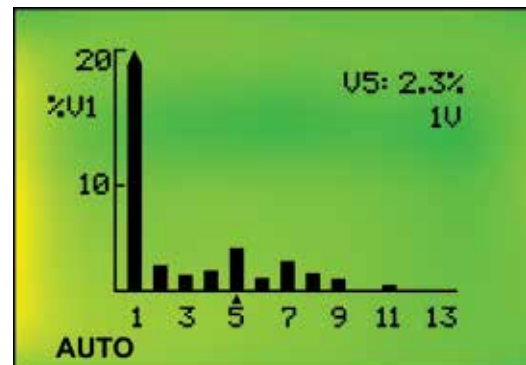

Modbus communication

The Modbus feature allows communication with a monitoring system. All RVT-D parameters are available (including harmonic spectrum and tables) through an RS485 Modbus adapter. All RVT-D parameters are accessible through Modbus and the locking switch allows to limit their access through the Modbus communication only.

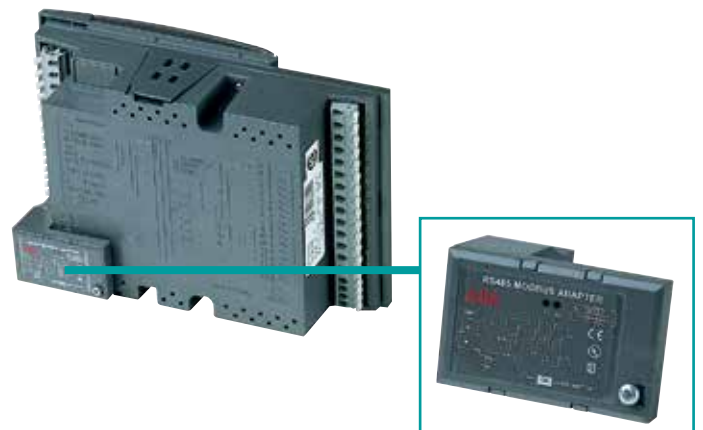

Components

The ABB CLMD capacitor consists of a number of wound elements made with a dielectric of metallized polypropylene film. It offers the following advantages:

Dry type design

The CLMD has a dry type dielectric and therefore cannot give any risk of leakage or pollution to the environment.

In-house metallized film

The dry dielectric of the CLMD is made of ABB in-house metallized polypropylene film giving:

- High voltage withstand capability
- Excellent peak current handling capacity
- High capacitance stability
- Long life even under high electrical stress
- Very low losses
- Exceptional self-healing properties

Unique sequential protection system

A unique sequential protection system ensures that each individual element can be disconnected from the circuit at the end of its life.

High level of safety

Capacitor elements are encapsulated in a thermo-setting resin and placed in a sheet steel box filled with inorganic, inert and fire proof granules (vermiculite) that will absorb the energy produced or extinguish any flames in case of a possible defect at the end of an element's life. Thermal equalizers are fitted to surround each capacitor element and provide effective heat dissipation.

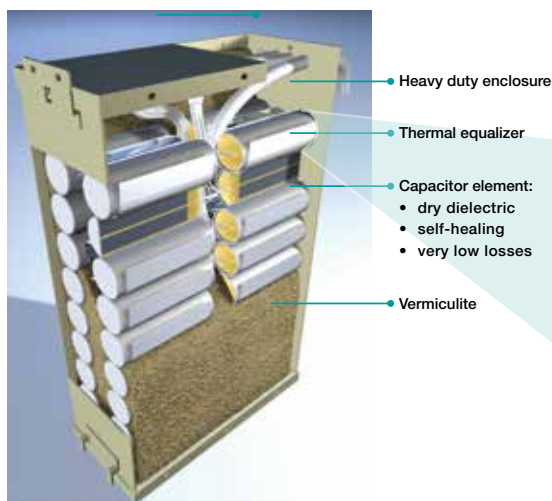

CLMD capacitor

ABB Reactors

Most applications where dynamic reactive power compensation is required, are associated with non-linear loads, producing significant harmonics. In order to safeguard the capacitors from harmonic overloading and also to perform limited filtering action, the capacitors in the Dynacomp are provided with a suitable detuning reactor. The choice of the detuning reactor is based on our long experience, to suit the actual harmonic spectrum present in different type of loads.

Reactors are iron cored with copper or aluminium windings and copper terminals. Units are completely impregnated under vacuum and overpressure in a polyester resin and dried in furnace. The reactors are designed for heavy industrial environments. For extremely polluted networks, re-inforced reactors are offered as an option.

Dynaswitches

- The Dynaswitch is the electronic switch of the Dynacomp controlling the connection of the capacitors to the network.
- The Dynaswitch is composed of two pairs of back-to-back high power thyristor modules, governing the passage of current.
- As only full alternations of current are allowed, the Dynaswitch does not act as a classical AC thyristor valve for which the firing pulses of the thyristors are chosen to modulate the current. It plays the role of a classical mechanical interrupter, with the possibility to choose explicitly the closing instant. The interest is to avoid transients. The opening instant occurs at zero crossing of the current, as thyristors are used.
- The Dynaswitch is also equipped with its own cooling device, ensuring a normal working temperature for the semiconductors. The complete system is protected by fuses.
- The improved Dynaswitch controller allows CAN bus communication and offers a compact design. It also enhances error reporting.

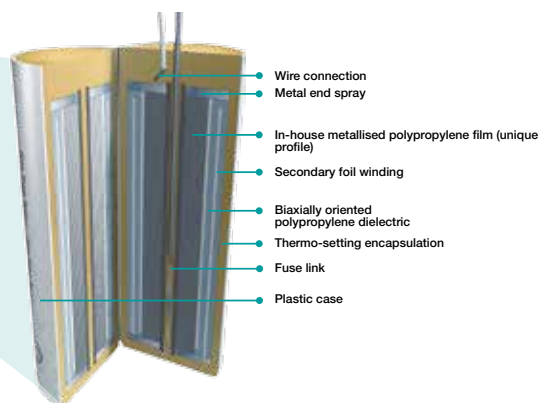

Typical applications

Harbour crane

Switching of charged capacitors result in large transients when the capacitor and network voltages are in phase opposition at the closing instant. This is why conventional banks always have delays (~1 minute) between switching on/off the capacitors. This delay permits the discharge of the capacitors through discharge resistors, but limits the utilisation of conventional capacitor banks for rapidly fluctuating loads requiring frequent switchings.



As the switching of the Dynacomp does not require the discharge of the capacitors, the utilisation of the Dynacomp for the compensation of any load with rapid variations is possible. During its cycle, a crane requires variable amounts of reactive power. The whole crane cycle lasts about one minute. Compensation with conventional banks is not possible for this operation: the cycle is too short and the required reactive power is too large. The Dynacomp improves the power factor by reducing the reactive current drawn from the grid. This also results in reduced current drawn from the supply system. The presence of 7% detuning reactor helps in harmonic absorption which is reflected in reduced THDV levels.

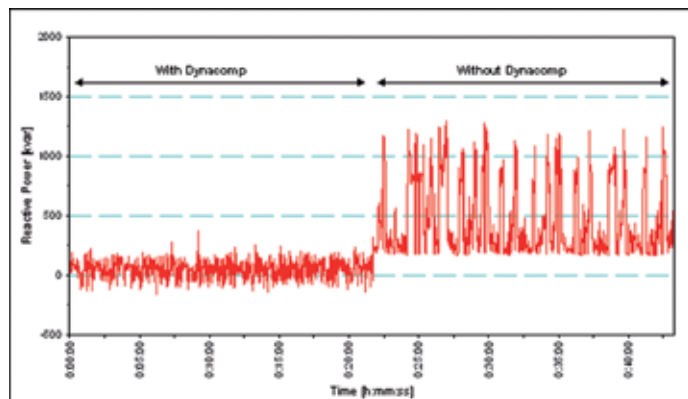

Reactive Power (kvar) with and without Dynacomp

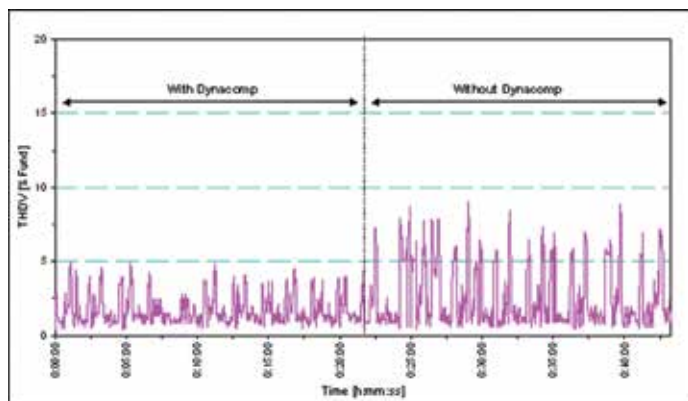

Total harmonic voltage distortion (THDV) with and without Dynacomp

Welding machine

Welding equipment typically draws high welding current for a very short time. As a result, the repetitive impermissible voltage variations may result.



In the figures below, 4 steps of 150 kvar are switched on for the compensation of a 210 kVA single phase welder with the use of an external signal for instantaneous response time (voltage drop compensation). These figures show clearly that the voltage drop due to the welding machine is totally reduced. Perturbation to sensitive devices like PLC, computers, lighting, ... are avoided.

In addition to this positive effect, the quality of the welding is considerably improved leading to a better quality of the final product. At the same time the power consumption of the production line is significantly lowered.

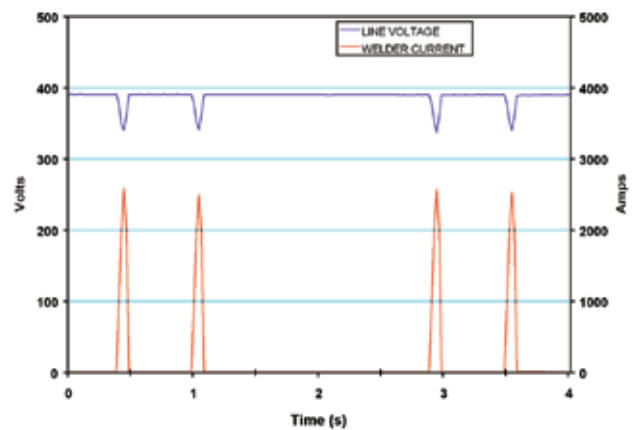

Without Dynacomp

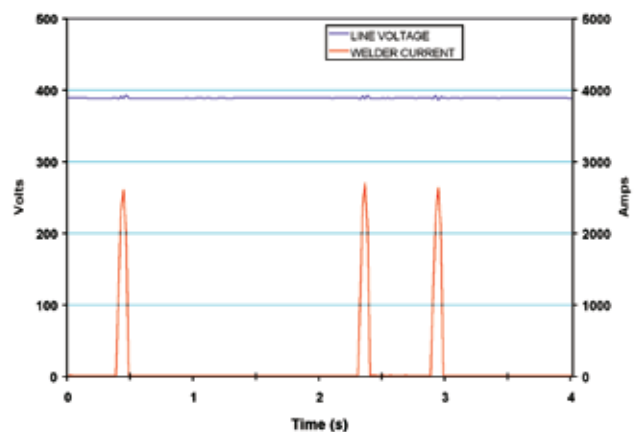

With Dynacomp

Typical applications

Rolling mill

Rolling mill normally employs large DC drives where the metal is rolled from billets to various sheet thicknesses. The load on the network depends on the type of "Pass" and grade of material being rolled. A typical load cycle lasts from a few minutes to several minutes during which the reactive power demand varies rapidly.



A classical solution employing contactors as switching device can not properly compensate the load of a rolling mill. The Dynacomp due to its superior performance is the ideal solution for rolling mill applications.

The Dynacomp successfully performs the task of reactive compensation, reducing the reactive power drawn from the supply network and hence improving the power factor. The reduced line current helps in loss reduction of the overall system. The reduced voltage distortion due to harmonic absorption by the Dynacomp is an added advantage. The stable bus voltage means a better quality of the finished product. All these add to the overall efficiency of the complete system.

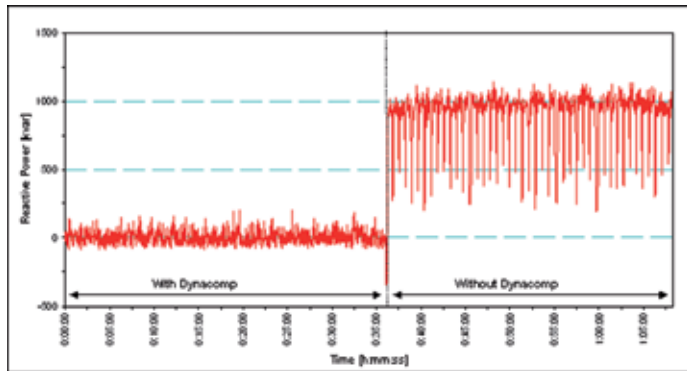

Reactive Power (kvar) with and without Dynacomp

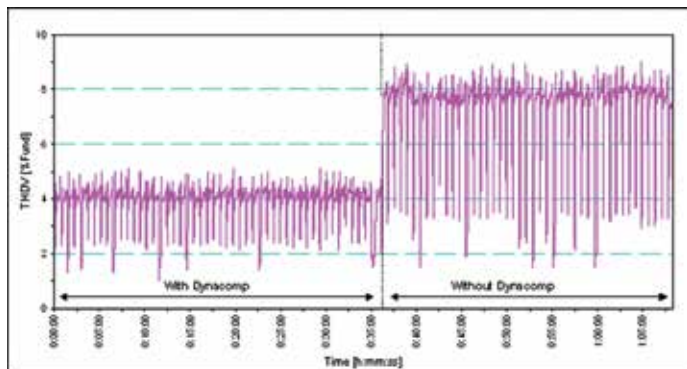

Total harmonic voltage distortion (THDV) with and without Dynacomp

Oil drilling platform

Offshore platforms normally use onboard generators to power the electrical loads. These loads consume high active power (kW) at very low $\cos \phi$ implying a very high reactive (kvar) power



As a result, most of these platforms run more number of generators than needed to meet the active power (kW) demand. This results in high operation and maintenance costs of the generators. A suitably rated Dynacomp relieves the generators from extreme reactive power burden and lets them operate at optimal $\cos \phi$. This results in a significant reduction in load current to be supplied by the generators and as a consequence some of the generators can be switched off. It gives direct benefit in terms of saved fuel and maintenance cost apart from other benefits thanks to the improved $\cos \phi$. production line is significantly lowered.

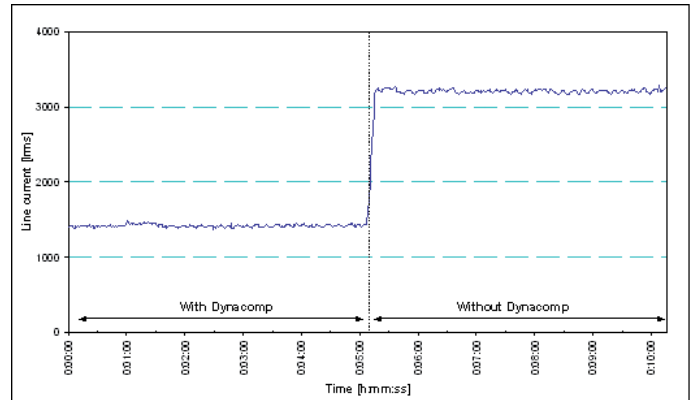

Line current (Irms) with and without Dynacomp

Steps	Power Factor	Line Current (Arms)	Current Reduction (%)
0	0.46	3160	0
1	0.48	2925	7.4
2	0.52	2720	13.9
3	0.55	2565	18.8
4	0.59	2365	25.2
5	0.63	2205	30.2
6	0.68	2035	35.6
7	0.75	1860	41.1
8	0.79	1705	46.0
9	0.86	1585	49.8

Technical specifications

Rated voltage	Three-phase 50 Hz: 380/400V - 415V - 525V - 600V - 660/690V Three-phase 60 Hz: 380V - 480V - 600V - 660/690V Single-phase 50 Hz: 380/400V - 415V - 600V - 660/690V Single-phase 60 Hz: 380V - 480V - 600V - 660/690V
Rated power and modular design	From 150 up to 400 kvar in one single cubicle. Master and slave(s) cubicle(s) can be combined up to 12.8 Mvar.
Step size	50, 100, 200 and 400 kvar.
Maximum number of steps	32 (CAN control) - 12 (opto isolated).
Physical output(s)	1 to 4 per cubicle.
Capacitor	CLMD technology. Dry type self healing. Designed as per IEC-80631-1&2.
Detuning reactor	7% for 3-phase system. 14% for 1-phase system. (Other values, please consult us)
Tolerance	± 10% in voltage. ± 5% in frequency.
CT requirements	1 CT required (class 1.0 or better). 1 or 5 A secondary.
Communication	Using Modbus RTU.
Programming	Using RVT-D controller.
Response time	Closed loop: < 3 cycles. Open loop: < 1 cycle. External trigger: instantaneous.
Color	RAL 7035.
Protection degree	IP21 (touch proof with door open).
Cable entry	Top (optional bottom cable entry cubicle).
Ambient temperature	-10°C to +40°C max. average.
Installation	Free floor standing.
Environment	Indoor installation in clean environment up to 1000 m altitude
Humidity	Maximum 95% non-condensation.
Possible features	Base frame. Main breaker. Cable entry cubicle with bus bar (Bottom cable entry). Temperature probes. Surge arresters. IP43 protection. RS485 converter. Reinforced reactors. 5.67% detuning reactors. Special reactor execution. Tinned bus bars. Dampers.

Contact us

ABB n.v.

Power Quality Products

Avenue Centrale 10

Zoning Industriel de Jumet

B-6040 Charleroi (Jumet), Belgium

Phone: +32(0) 71 250 811

Fax: +32 (0) 71 344 007

E-Mail: Power.Quality@be.abb.com

www.abb.com/lowvoltage

While all care has been taken to ensure that the information contained in this publication is correct, no responsibility can be accepted for any inaccuracy. We reserve the right to alter or modify the information contained herein at any time in the light of technical or other developments. Technical specifications are valid under normal operating conditions only. We do not accept any responsibility for any misuse of the product and cannot be held liable for indirect or consequential damages.