



Small soft starters with integral by-pass

ASTAT S is compact, easy to operate soft starter, designed for use with standard 3-phase squirrel cage motors. It provides an advanced method of reducing current during motor starting and stopping. ASTAT S will start supplying a reduced voltage to the motor, increasing up to the rated voltage, so avoiding, high currents and generating soft starting and stopping. The motor has to be able to start in a reduced voltage.

- Solid soft starter for standard 3ph AC motors up to 30kW at 400V AC
- Voltage ratings up to 600V
- Two phase control with integral by-pass
- Compact, small case
- DIN rail mounting. Optional from 31A
- Start and soft stop features

Marking



The cUL, is achieved for all range of ASTAT S, except for 58A models, items QA02P058S, QA12P058S, QA22P058S, QA32P058S.

Technical data

Ratings

Voltage ratings	3ph AC systems 220/230V (+10%, -15%) for units QA02P___ S 380/415V (+10%, -15%) for units QA12P___ S 480/500V (+10%, -15%) for units QA22P___ S 575/600V (+10%, -15%) for units QA32P___ S
Frequency range	50/60Hz (±5%)
Load	3ph, AC standard motors

Control specifications

Ramp up	0,5 - 10 s
Ramp down	0,5 - 10 s
Initial voltage	0 - 80% Un
Starting torque	0 - 64% Tn

I/O control

Inputs	one input for Start/Stop
Outputs	one output for «End of Ramp» signal for ratings 31, 44, 58A

Ambient conditions

Operating temperature	0 to 40°C. Up to 60°C derating by 1,2% per °C
Storage temperature	-20 to 70°C
Relative humidity	up to 80%, without condensation
Max. altitude	up to 1000m. Above this derate by 5% each 100m
Protection degree	IP20

- Order codes ● page 1.3
- Diagrams ● page 1.4
- Performances ● page 1.5
- Dimensions ● page 1.6



Small soft starters with integral by-pass



Input voltage V/CA	Current rating (2) A	Maximum current A	Maximum motor power (1)				Cat. No.	Ref. no.	Pack
			220/230V kW / Hp	380/415V kW / Hp	480/500V kW / Hp	575/600V kW / Hp			
220	8	28	1.5 / 2	-	-	-	QA02P008S	120881	1
	17	60	4 / 5.5	-	-	-	QA02P017S	120882	1
	22	77	5.5 / 7.5	-	-	-	QA02P022S	120883	1
	31	110	7.5 / 10	-	-	-	QA02P031S	120884	1
	44	150	11 / 15	-	-	-	QA02P044S	120885	1
	58	200	15 / 20	-	-	-	QA02P058S	120886	1
400	8	28	-	4 / 5.5	-	-	QA12P008S	120892	1
	17	60	-	7.5 / 10	-	-	QA12P017S	120893	1
	22	77	-	11 / 15	-	-	QA12P022S	120894	1
	31	110	-	15 / 20	-	-	QA12P031S	120895	1
	44	150	-	22 / 30	-	-	QA12P044S	120896	1
	58	200	-	30 / 40	-	-	QA12P058S	120897	1
500	8	28	-	-	5.5 / 7.5	-	QA22P008S	120898	1
	17	60	-	-	11 / 15	-	QA22P017S	120899	1
	22	77	-	-	15 / 20	-	QA22P022S	120900	1
	31	110	-	-	22 / 30	-	QA22P031S	120901	1
	44	150	-	-	30 / 40	-	QA22P044S	120902	1
	58	200	-	-	45 / 60	-	QA22P058S	120903	1
600	8	28	-	-	-	7.5 / 10	QA32P008S	120904	1
	17	60	-	-	-	15 / 20	QA32P017S	120905	1
	22	77	-	-	-	22 / 30	QA32P022S	120906	1
	31	110	-	-	-	30 / 40	QA32P031S	120907	1
	44	150	-	-	-	37 / 50	QA32P044S	120908	1
	58	200	-	-	-	55 / 75	QA32P058S	120909	1
Accessory	DIN rail mounting kit for types 31A, 44A and 58A						QAOPDIN	120910	1

(1) Ratings for standard 4-poles AC motors
 (2) See Operations/hour in table below
 Cycles/hour includes both soft start and soft stop

Times between rampings Start/Stop

	Starting current	Ramp 1 sec.	Ramp 2 sec.	Ramp 5 sec.	Ramp 10 sec.
QA_2P008S	8	7	15	35	70
	16	16	33	77	155
	24	26	51	125	250
	28 (*)	32	62	155	-
QA_2P017S	17	7	15	35	70
	34	16	33	77	155
	51	26	51	125	250
	60 (*)	32	62	155	-
QA_2P022S	22	7	15	35	70
	44	16	33	77	155
	66	26	51	125	250
	77 (*)	32	62	155	-
QA_2P031S	31	4	8	20	40
	62	8	15	38	76
	93	12	24	62	124
	110 (*)	15	31	80	-
QA_2P044S	44	4	8	20	40
	88	8	15	38	76
	132	12	24	62	124
	155 (*)	15	31	80	-
QA_2P058S	58	4	8	20	40
	116	8	15	38	76
	174	12	24	62	124
	200 (*)	15	31	80	-

(*) Maximum starting current at all

Small soft starters

Intro

A

B

C

D

E

F

G

H

I

J/X



Diagrams

Control by permanent command (soft start and stop)

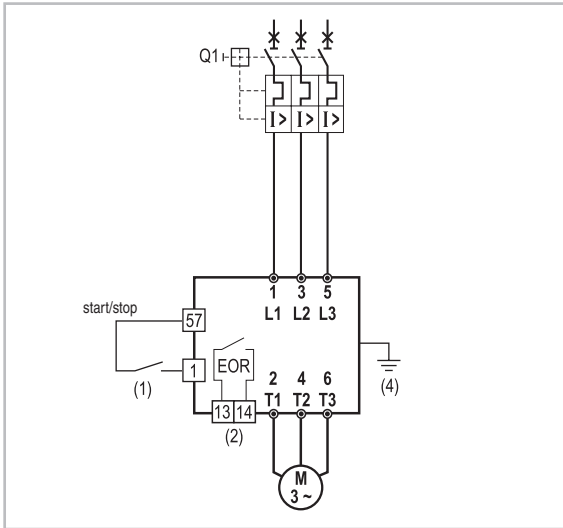

Control by push-buttons, line contactor and thermal overload relay (soft start)

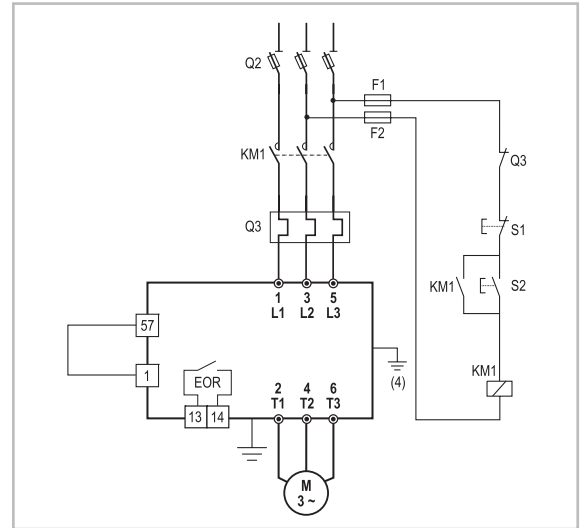

Control by push-buttons and line contactor (soft start)

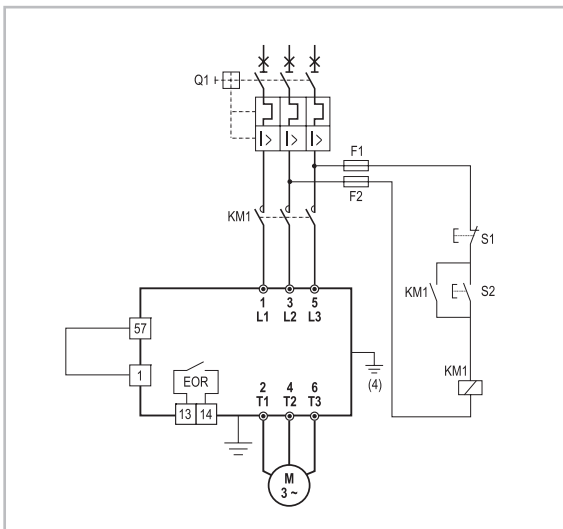

Forward/reverse control by push-buttons (3)

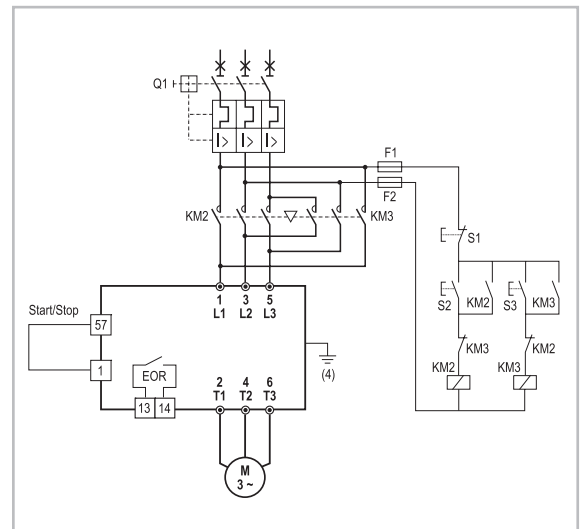

Motor power 380/415V		ASTAT S	Q1	Q2	KM1	Q3	F1-F2	S1-S2-S3
kW	Hp			Am fuses	Contactor	Thermal overload relay		
4	5.5	QA12P008	GPS1B*AK	10	CL25A	RT A 1N	-	P9-P3
7.5	10	QA12P017	GPS1B*AN	25	CL25A	RT A 1S	-	P9-P3
11	15	QA12P022	GPS1B*AP	32	CL25A	RT A 1T	-	P9-P3
15	20	QA12P031	GPS1B*AR	40	CL04A	RT A 1V	-	P9-P3
22	30	QA12P044	GPS2B*AT	63	CL06A	RT A 2F	-	P9-P3
30	40	QA12P058	GPS2B*AU	80	CL07A	RT A 2H	-	P9-P3

Coordination type 1

- (1) Use dry contact only.
- (2) End of Ramp output relay (only types 31A, 44A and 58A).
- (3) Forward/Reverse operation must be done when motor is not rotating.
- (4) Ground terminal only for types 31A, 44A and 58A.



Performances

Direct-on-line start

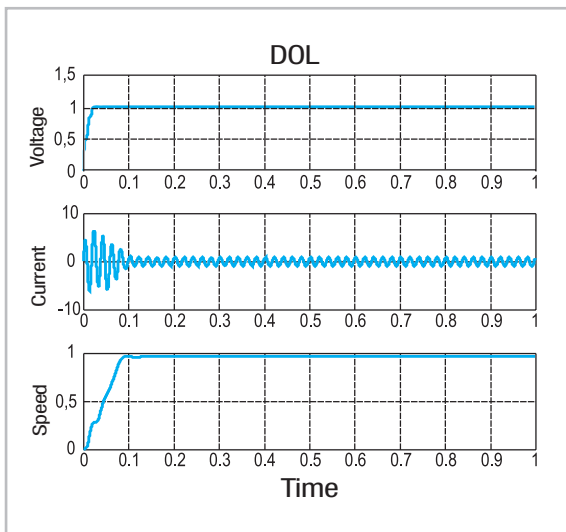

ASTAT S soft start

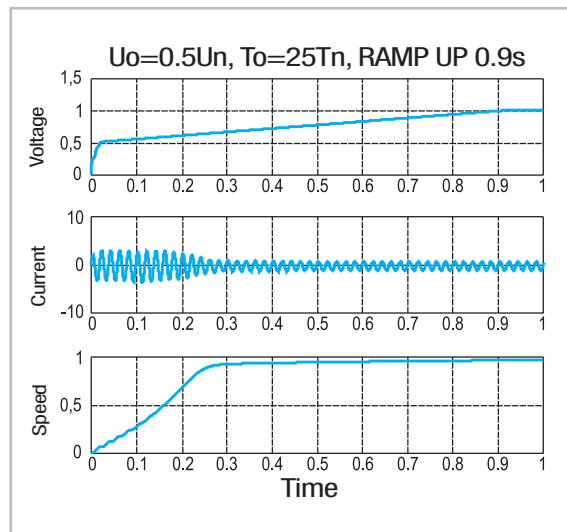

Direct-on-line stop

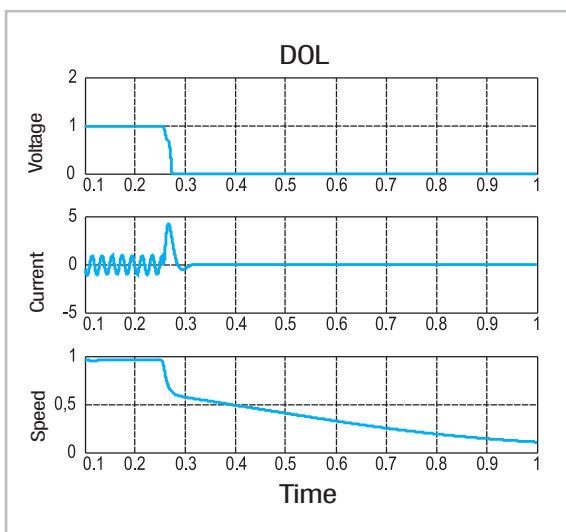

ASTAT S soft stop

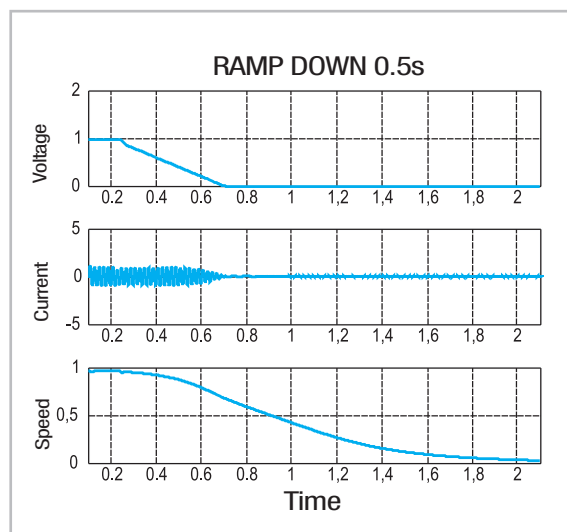

Dimensional drawings

Small soft starter with integral by-pass

TYPE	Weight (kg)
QA12P008S	0.470
QA22P008S	0.470

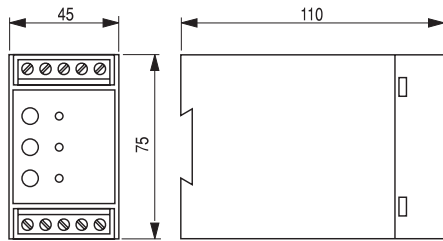

Dimensions in mm

TYPE	Weight (kg)
QA_2P017S	0.610
QA_2P022S	0.650
QA32P008S	0.650

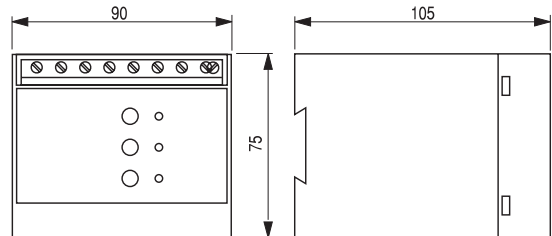

Dimensions in mm

TYPE	Weight (kg)
QA_2P031S	1.370
QA_2P044S	1.400
QA_2P058S	1.400

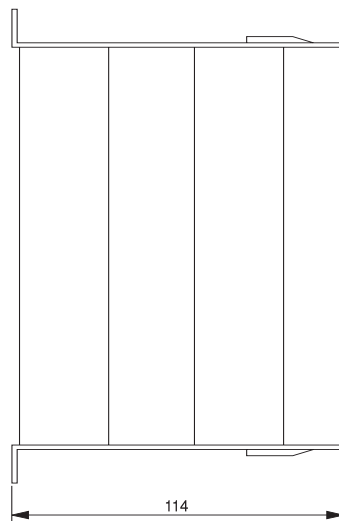
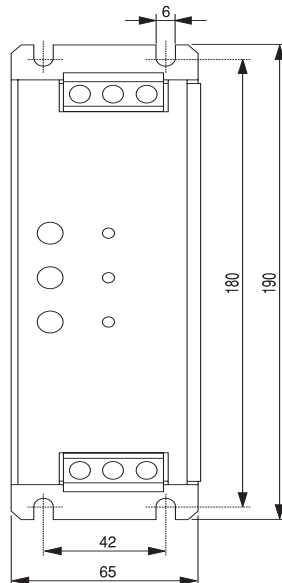
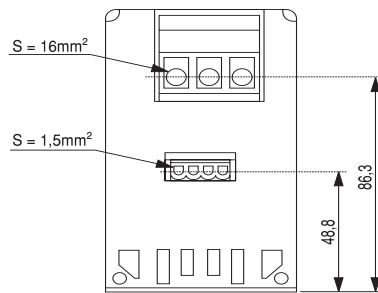

Dimensions in mm

ASTAT XT

Digital soft starters for 3ph standard induction motors

GE's new ASTAT XT solid state soft starter features microprocessor control digital technology. Setup and adjustment is performed through a six-button keypad and parameters or messages are displayed out through a friendly LCD multilanguage interface with two rows, sixteen alphanumeric characters each. The design includes isolated I/O and high level of protection in their circuits to minimize the disturbance effects while working in the hardest industrial environment.

ASTAT XT Soft Starter offers reliable performance and smooth acceleration for a variety of standard AC motors up to 1400A and up to 690V, reducing mechanical shock to the driving system, resulting in extended component and motor life.

ASTAT XT offers many traditional features such a motor overload function, adjustable ramps, current limit, kick start, but also other high end features like inside-delta operation, torque control, pump control and a reliable motor and unit set of protections.

Key Features

- Ratings up to 1400Amps and up to 690VAC
- Friendly multilanguage interface with two rows, sixteen characters each
- Built-in with three extra power terminals for external bypass
- In-line or inside-delta operation modes
- Torque control and pump control advanced features
- Motor protection according IEC 10, 20 and NEMA 10, 20, 30, even if ASTAT XT is in by-pass
- Built in communications RS485 port, and ModBus protocol as standard
- ProfibusDP and DeviceNet optional interfaces for communications



Approvals / Marking



For units up to 820A. "U" type



(Contact GE for details)

Control panel



- Order codes ● pg. I.8
- Technical data ● pg. I.11
- Functions ● pg. I.12
- Overload protections ● pg. I.13
- I/O wiring ● pg. I.14
- Wiring diagrams ● pg. I.16
- Coordination types ● pg. I.20
- Dimensions ● pg. I.22



IEC ratings. Recommended motor and type unit ratings

Soft starters

	Mains voltage	Light Duty	NORMAL DUTY (IEC Class 10)				HEAVY DUTY (IEC Class 20)				Cat. No.	Ref. No.		
		Max Current Rating	Rated Current	400V-230V	480V-415V	500V-415V	690V	Rated Current	400V-230V	480V-415V			500V-415V	690V
		A	A	kW	kW	kW	kW	A	kW	kW			kW	kW
Mains voltage 230-500VAC	8	8	1.5	3	4	-	8	1.5	3	4	-	QT10008U21MS	169075	
	17	17	4	7.5	7.5	-	12	3	5.5	5.5	-	QT10017U21MS	169076	
	34	31	7.5	15	18.5	-	31	7.5	15	18.5	-	QT10031U21MS	169077	
	54	44	11	22	30	-	44	11	22	30	-	QT10044U21MS	169078	
	65	58	15	30	37	-	55	15	30	37	-	QT10058U21MS	169079	
	72	72	22	37	45	-	66	18.5	37	45	-	QT10072U21MS	169080	
	104	85	22	45	55	-	80	22	45	55	-	QT10085U21MS	169081	
	130	105	30	55	55	-	99	30	55	55	-	QT10105U21MS	169082	
	156	145	45	75	90	-	130	37	55	90	-	QT10145U21MS	169083	
	170	170	55	90	110	-	134	37	75	90	-	QT10170U21MS	169084	
	248	210	55	110	132	-	203	55	110	132	-	QT10210N21MS	169091	
	361	310	90	160	200	-	310	75	160	200	-	QT10310N21MS	169092	
	390	390	110	200	250	-	344	110	160	250	-	QT10390N21MS	169093	
	480	460	132	250	315	-	432	132	250	315	-	QT10460N21MS	169094	
	610	580	160	315	400	-	488	160	250	355	-	QT10580N21MS	169095	
	610	580	160	315	400	-	552	160	315	400	-	QT10580U21MS	169089	
	820	650	200	355	400	-	552	160	315	400	-	QT10650N21MS	169096	
820	820	250	400	560	-	690	200	400	500	-	QT10820U21MS	169090		
1180	950	315	560	630	-	950	315	560	630	-	QT10950N21MS	169097		
1375	1100	355	630	800	-	1076	355	630	800	-	QT11100N21MS	169098		
1750	1400	400	800	1000	-	1400	400	800	1000	-	QT11400N21MS	169099		
Mains voltage 690VAC	8	8	-	-	-	5.5	8	-	-	-	5.5	QT30008N21MS	169119	
	17	17	-	-	-	15	12	-	-	-	7.5	QT30017N21MS	169120	
	34	31	-	-	-	22	31	-	-	-	22	QT30031N21MS	169121	
	54	44	-	-	-	37	44	-	-	-	37	QT30044N21MS	169122	
	65	58	-	-	-	55	55	-	-	-	45	QT30058N21MS	169123	
	72	72	-	-	-	55	66	-	-	-	55	QT30072N21MS	169124	
	104	85	-	-	-	75	80	-	-	-	75	QT30085N21MS	169125	
	130	105	-	-	-	90	99	-	-	-	90	QT30105N21MS	169126	
	156	145	-	-	-	132	130	-	-	-	90	QT30145N21MS	169127	
	170	170	-	-	-	160	134	-	-	-	132	QT30170N21MS	169128	
	248	210	-	-	-	200	203	-	-	-	200	QT30210N21MS	169129	
	361	310	-	-	-	250	310	-	-	-	250	QT30310N21MS	169130	
	390	390	-	-	-	355	344	-	-	-	315	QT30390N21MS	169131	
	480	460	-	-	-	400	432	-	-	-	400	QT30460N21MS	169132	
	610	580	-	-	-	560	488	-	-	-	400	QT30580N21MS	169133	
	820	650	-	-	-	630	552	-	-	-	560	QT30650N21MS	169134	
	1180	950	-	-	-	900	950	-	-	-	900	QT30950N21MS	169135	
1375	1100	-	-	-	1000	1076	-	-	-	1000	QT31100N21MS	169136		
1750	1400	-	-	-	-	1400	-	-	-	-	QT31400N21MS	169137		

Remark

Motor kW ratings given in above table are for IEC, standard AC four poles motors. Always check that motor rated current is less than the specified rated current of the starter, for the specific application (Normal Duty or Heavy Duty)



QT10008U21MS
ASTAT XT 8A-72A



QT10105U21MS
ASTAT XT 105A-170A



QT10210N21MS
ASTAT XT 210A-390A



QT10460N21MS
ASTAT XT 460A-650A



Intro
A
B
C
D
E
F
G
H
I
J/X

NEMA ratings. Recommended unit type and motor ratings

	LIGHT DUTY Nema 10				NORMAL DUTY Nema 20				HEAVY DUTY Nema 30				Cat. No.	Ref. No.
	Current Rating		Current Rating		Current Rating		Current Rating		Current Rating		Current Rating			
	230V	460V	575V	230V	460V	575V	230V	460V	575V	230V	460V	575V		
Mains voltage 230-500VAC	A	HP	HP	HP	A	HP	HP	HP	A	HP	HP	HP		
	8	2	5	-	8	2	5	-	8	2	5	-	QT10008U21MS	169075
	17	5	10	-	17	5	10	-	12	3	7.5	-	QT10017U21MS	169076
	34	10	25	-	31	10	20	-	31	10	20	-	QT10031U21MS	169077
	54	20	40	-	44	15	30	-	44	15	30	-	QT10044U21MS	169078
	65	20	50	-	58	20	40	-	55	20	40	-	QT10058U21MS	169079
	72	25	50	-	72	25	50	-	66	20	50	-	QT10072U21MS	169080
	104	40	75	-	85	30	60	-	80	30	60	-	QT10085U21MS	169081
	130	50	100	-	105	40	75	-	99	40	75	-	QT10105U21MS	169082
	156	60	125	-	145	50	100	-	130	50	100	-	QT10145U21MS	169083
	170	60	125	-	170	60	125	-	134	50	100	-	QT10170U21MS	169084
	262	100	200	-	210	75	150	-	203	75	150	-	QT10210U21MS	169085
	387	150	300	-	310	100	250	-	310	100	250	-	QT10310U21MS	169086
	414	150	350	-	390	150	300	-	361	150	300	-	QT10390U21MS	169087
	480	200	400	-	460	150	350	-	432	150	350	-	QT10460U21MS	169088
	610	250	500	-	580	200	400	-	552	200	400	-	QT10580U21MS	169089
820	-	-	-	820	250	500	-	690	250	500	-	QT10820U21MS	169090	
Mains voltage 460-600VAC	8	-	5	5	8	-	5	5	8	-	5	5	QT20008U21MS	169100
	17	-	10	15	17	-	10	15	12	-	7.5	10	QT20017U21MS	169101
	34	-	25	30	31	-	20	25	31	-	20	25	QT20031U21MS	169102
	54	-	40	50	44	-	30	40	44	-	30	40	QT20044U21MS	169103
	65	-	50	60	58	-	40	50	55	-	40	50	QT20058U21MS	169104
	72	-	50	60	72	-	50	60	66	-	50	60	QT20072U21MS	169105
	104	-	75	100	85	-	60	75	80	-	60	75	QT20085U21MS	169106
	130	-	100	125	105	-	75	100	99	-	75	100	QT20105U21MS	169107
	156	-	125	150	145	-	100	150	130	-	100	125	QT20145U21MS	169108
	170	-	125	150	170	-	125	150	134	-	100	125	QT20170U21MS	169109
	262	-	200	250	210	-	150	200	203	-	150	200	QT20210U21MS	169110
	387	-	300	400	310	-	250	300	310	-	250	300	QT20310U21MS	169111
	414	-	350	400	390	-	300	400	361	-	300	300	QT20390U21MS	169112
	480	-	400	500	460	-	350	400	432	-	350	400	QT20460U21MS	169113
	610	-	500	-	580	-	400	400	552	-	400	500	QT20580U21MS	169114
	820	-	-	-	820	-	500	500	690	-	500	-	QT20820U21MS	169115

Remark

Motor HP ratings given in above table are for NEMA, standard AC four poles motors. Always check that motor rated current is less than the specified rated current of the starter, for the specific application (Light duty, Normal duty or Heavy duty)



Unit configuration

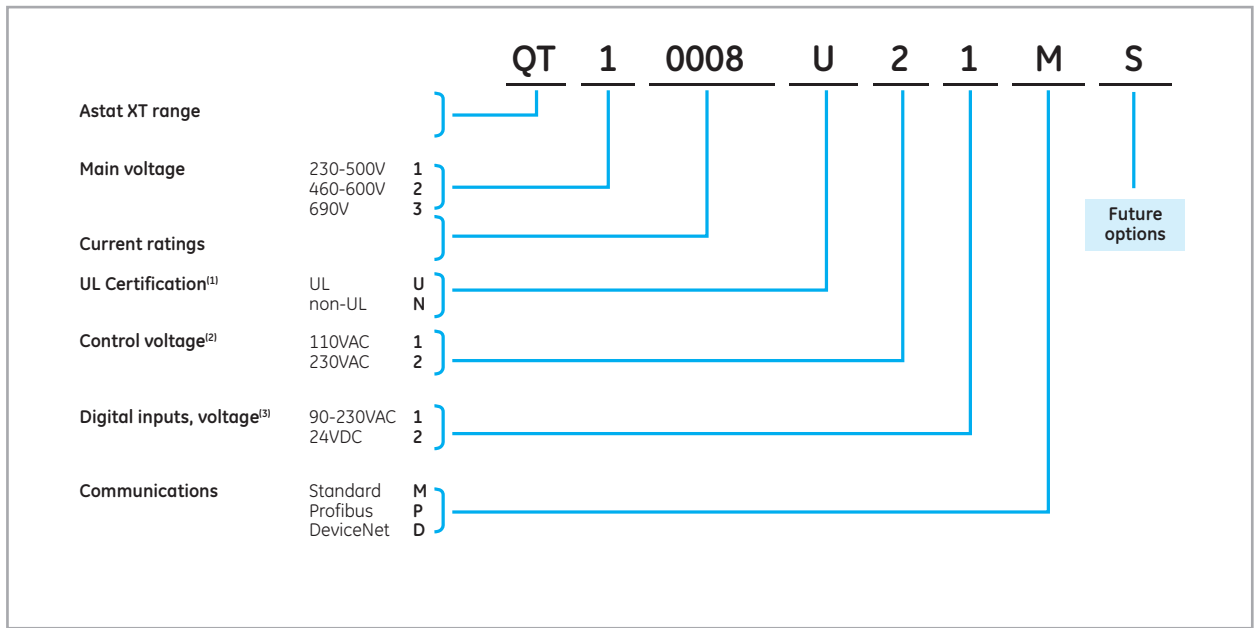

(1) - ASTAT XT up to 600V, and up to 170A (Cat Numbers up to QT10170_ or up to QT20170) are always cUL certified. Option "N" not available

- Units QT2, from QT20008_, up to QT20820_ are always cUL certified. Option "N" not available.

- Units QT1, or QT2 from QTx0950_ up to QTx1400 are not UL certified. Option "U" not available.

- Units QT3_, rated to 690V, are not UL certified. Option "U" not available

(2) ASTAT XT standard Control Voltage configuration is option 2, Voltage 230VAC, +10%, -15%

(3) ASTAT XT standard configuration for Inputs is option 1, Voltage 90-230VAC, +10%, -15%



Technical data

Ratings

Main voltage	3Ph AC supply	230 to 500VAC +10%, -15% for QT1xxx units 460 to 600VAC +10%, -15% for QT2xxx units 690VAC +10%, -15% for QT3xxx units
Starter current rating	for 3Ph AC motors	From 8A up to 1400A.
Motor current rating	3 phases induction motors	Motor rated current from 50% to 100% of starter current
Control voltage	1ph AC supply	230VAC, +10, -15%, 50/60Hz, or 110VAC, +10, -15%, 50/60Hz (optional)
Frequency range	50/60Hz systems	Wide from 45Hz to 65Hz. Auto-tracking frequency range

Control specifications

Control system	Digital control with microcontroller. Starting ramp, with progressive increase in voltage and current limitation
Operation mode	In-Line (three wires) or Inside-Delta (six wires) of the motor
Run operation	Soft Start and Soft stop by multiple choices, including torque control both at start or Stop phases
Operator interface	By LCD display, keypad and Indication LEDs Display: LCD with two rows, 16 characters each Type: Multilanguage, dip-switch selectable for English, Italian, Spanish and German Keys: Six keys, Mode, reset, Set, Select and Up / Down LEDs: ON, Start, Run, Soft Stop, Stop, Save / Slow Speed, Dual Set / Reverse and Fault
Initial voltage	10-50% Un. Up to 80% with expanded settings function
Starting current	100-400% In. Can be extended up to 500%, by using extended settings
Acceleration ramp time	1-30 sec. Can be extended up to 90sec, by using extended settings
Deceleration ramp time	1-30 sec. Can be extended up to 90sec, by using extended settings
Current limitation	100-400% of motor rated current. Can be extended up to 500% by using extended settings
Bypass	By external contactor while motor is full protected by ASTAT XT.
Monitoring	Motor Current, Line Voltage, motor thermistor resistance, Test & Maintenance and Statistics

Environmental conditions

Operating temperature	-10 up to 50°C, with current derating by 2.5% per °C, from 40°C
Storage temperature	-20°C up to 70°C
Maximum altitude	Up to 1000 mts. Ask your dealer for installation at higher altitude
Humidity	95% at 50°C or 98% at 45°C
Protection degree	IP20 for units up to 72A, IP00 for units from 85A up to 1400A
Pollution degree	Class 3

Standards

Global standards	CE for the full range. UL, cUL for specified units up to 820A
EMC emissions	EN 61000-6-4 CISPR 11 Class A
Immunity	EN 61000-6-2 ESD 8KV air, IEC 801-2; Electric RF field 10 V/m, 20-1000Mhz, IEC 801-3 Fast transients 2KV, IEC 801-4
Safety	EN 600947-1 Related to safety requirements. UL508C

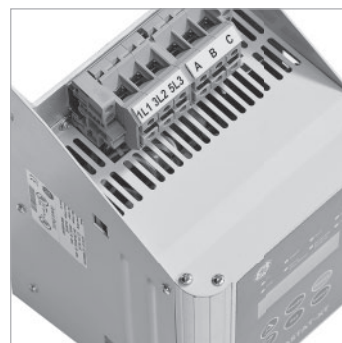

Intro

A

B

C

D

E

F

G

H

I

J/X



Functions

Available standard functions

Soft start and soft stop	ASTAT XT is provided with a soft start and soft stop features, including five independent acceleration and deceleration curve models. The factory default curve is used for general purpose, other three are used for pump control and the last one for torque control.
Pump control	Specific function for pump control, that avoids overpressure in the system at the end of acceleration phase and suppresses the hammering at stopping phase.
Torque control	Provides a smooth time controlled torque ramp acceleration and deceleration, with linear deceleration of the torque resulting in a close to linear speed deceleration, thus eliminating stall conditions
In line / Inside delta	ASTAT XT allows either traditional Line operation or Inside Delta operation. When the ASTAT XT is installed to operate Inside Delta, the individual phases of the starter are connected in series with the individual motor windings (six wiring connections like the Start-Delta starters), thus reducing the current x1.73, and allowing the use of a much smaller starter (x1.5 less than motor rated current).
Bypass	ASTAT XT allows bypass operation using an external contactor, controlled ON/OFF by starter function EOR (End Of Ramp). The starter is provided with three dedicated power terminals to facilitate wirings to the bypass contactor. ASTAT XT protections to motor are enabled, even in bypass.
Kick start	This function allows to start high friction loads that require high starting torque for a short period of time. When this function is enabled, a pulse of 80% Un during an adjustable time from 0 to 1sec is given to the motor. After this pulse the output voltage is ramping down to Starting Voltage setting, before ramping up again to full voltage.
End of ramp	Detects end of acceleration and outputs a signal by an dry relay contact. This signal can be delayed by an adjustable timer from 0-120 sec.
Lock-Out	Allows to control the number of startings into a period of time, then protecting both motor and ASTAT.
Dual settings	By this function, ASTAT XT is able to control a secondary motor Dual setting of Starting Voltage, Starting Current, Current Limit, Ramp Up, Ramp Down and Motor current parameters can be selected by using one of the programmable ASTAT XT's inputs
Energy saving	Activated when the motor has a light load for extended periods of time, then reducing the output voltage level and decreasing the reactive current and motor copper/iron losses. This function can be enabled or disabled by dedicated parameters in ASTAT XT.
Slow speed	Function that allows the motor to run at 1/6 constant rated speed, for a short period of time of maximum 30sec. This function supports forward and reverse operation.
Auto reset	This function allows the ASTAT XT automatic recover after a fault caused by Undervoltage, Undercurrent or Phase lost. Auto-Reset can be programmed up to maximum 10 attempts.
Cooling fan control	Allows three methods of control for the ASTAT's built-in cooling fans. - Continuous Operation - Controlled by an external Input - Automatically OFF controlled, after five minutes ASTAT XT is stopped
Generator supply	This is a specific function useful when the Starter is powered from a diesel generator rather than from commercial power supply. The function is enabled by an internal Dip Switch, and helps to minimize the negative effects caused by the generator's voltage fluctuations during starting.
Keypad lock	This function is enabled by means of starter's internal dipswitch, then locking the keypad. This is useful to prevent undesired parameter modifications.
Built-in communications	ASTAT XT includes a ModBus RTU communications protocol. Communications are carried out through a half duplex RS485 port, with maximum baudrate of 9600, supporting up to 247 stations.
Statistic data	ASTAT XT records useful data for maintenance and start up - Last 10 trip events - Statistical data like number of starts, number of trip events and elapsed RUN time. - Last trip data information of Motor current, Starting current and acceleration time.

Motor and starter protection

Overload	Trips the ASTAT-XT when current exceeds the Overload Trip level according IEC Class 10, 20 or NEMA 10, 20, 30
Motor thermistor	Trips when motor thermistor resistance decreases below trip level set ASTAT XT allows both PTC or NTC sensors, with adjustable trip level
Too many starts	Trips if the number of starts, during Duty Cycle Time exceeds the preset number
Long start time	Trips if output voltage does not reach rated voltage at the preset Max. Start time
O/C JAM fault	Trips under the following conditions: - Instantaneously when current exceeds 8.5 x ASTAT-XT Current - During starting when current exceeds 8.5 x Motor Current - During running when current exceeds 200-850% of Motor Current O/C JAM has a programmable tripping delay of 0-5 seconds
Undercurrent	Trips when line current drops below the preset level for the preset time.
Undervoltage	Trips when line voltage drops below the preset level for the preset time.
Overvoltage	Trips when line voltage increases above a preset level for a preset time
Phase loss	Trips if 1 or 2 phases are lost
Frequency loss	Trips if frequency is not in the range of 40-66.6Hz
Phase sequence	Trips if line phase sequence is wrong
Slow speed time	Trips when operating at slow speed for extended periods
Wrong connection	Trips the ASTAT-XT when one or more motor phases is not properly connected to ASTAT-XT's load terminals or if there is an internal disconnection in the motor winding
Shorted SCR	Trips and prevents starting if any SCR is short-circuited or when motor windings are shorted
Over temperature	Heat-sink over-temperature. Trips the ASTAT-XT when the heat-sink temperature rises above 85°C
External fault	Trips the ASTAT-XT when a N.O. contact between terminals 19-21 closes for over two seconds
Wrong parameters	Parameters not transferred from RAM to EEPROM or vice versa
OC or wrong CON	Trips when the ASTAT-XT is connected Inside Delta and Wrong connection or overcurrent is detected



Overload protections - Thermal characteristics

The ASTAT XT allows motor protection according IEC Class 10 or Class 20 and NEMA 10, 20 or 30, user free selectable by ASTAT internal dedicated parameter.

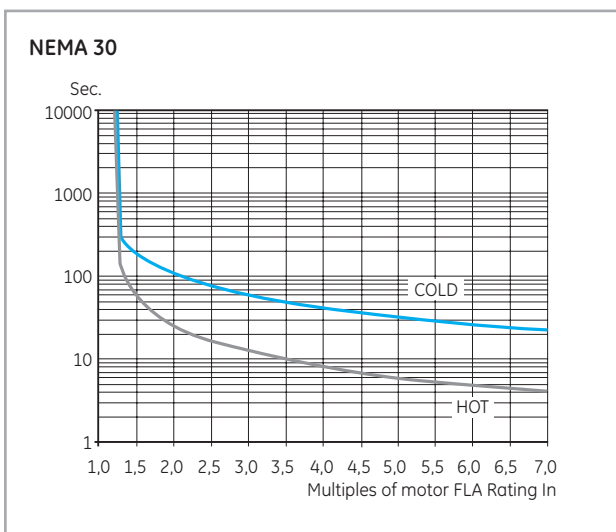
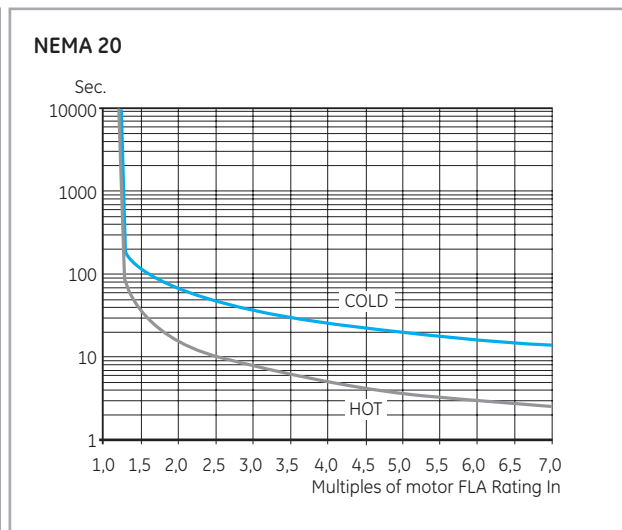
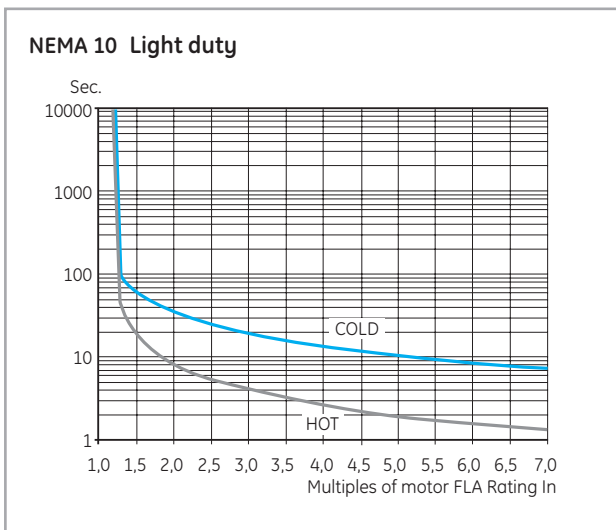
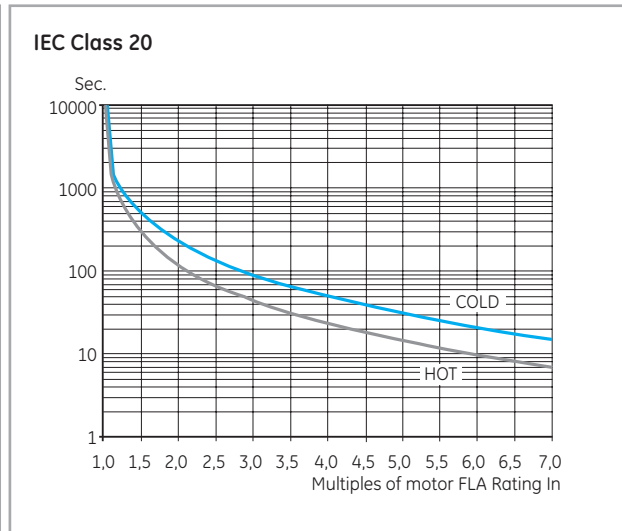
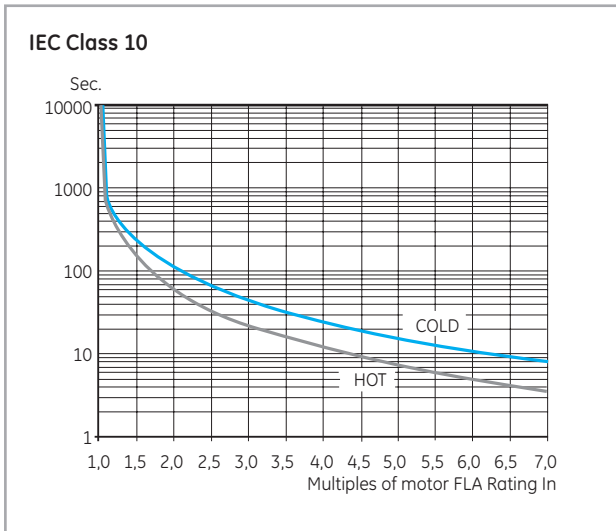

Maximum number starting /hour

Starting current I/In ⁽¹⁾	Ramp time		
	10s	20s	30s
2	24	12	8
3	16	8	5
4	12	6	4

(1) In= rated current of ASTAT XT in the specified class IEC/Nema



I/O Wiring, Basic scheme

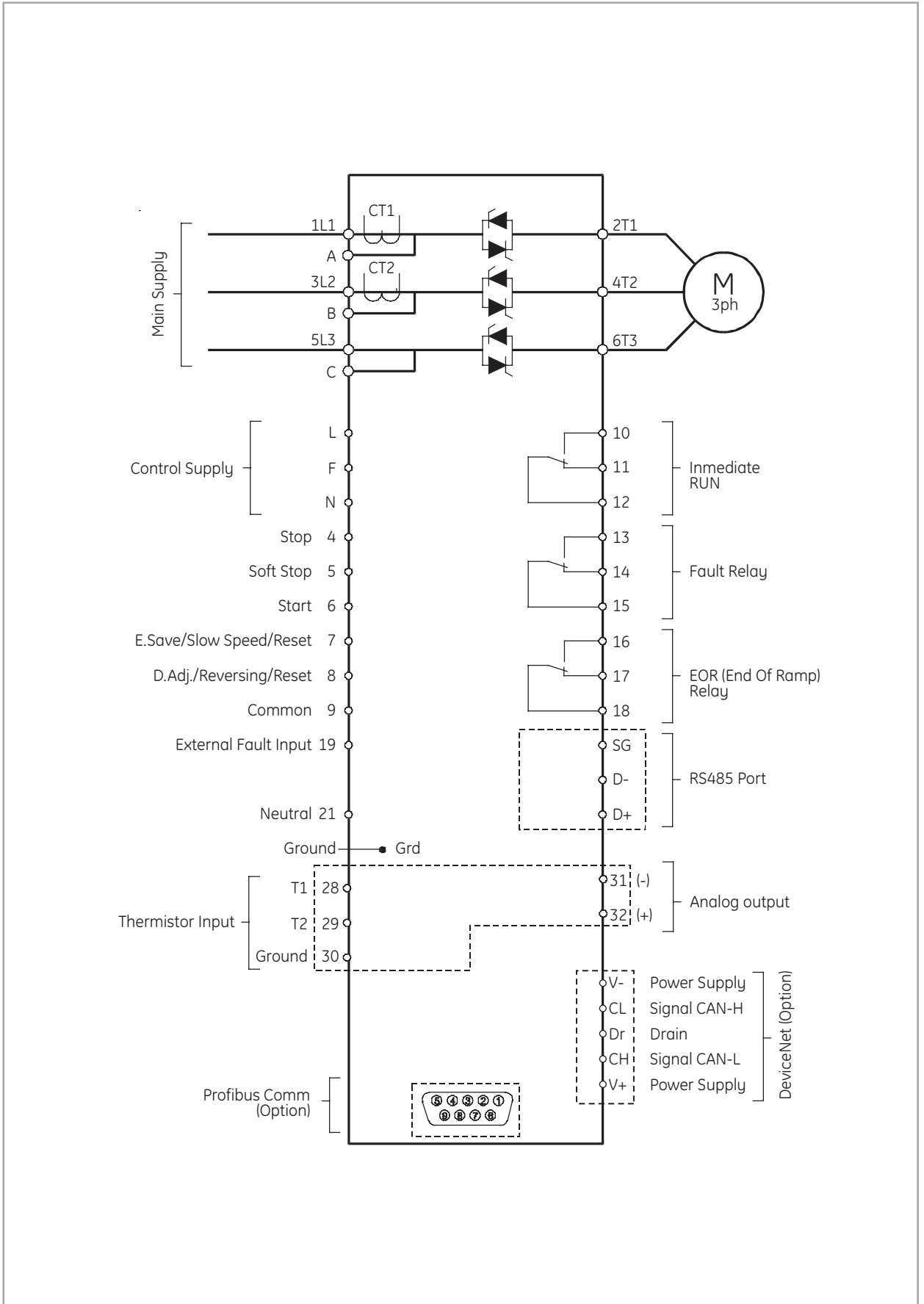

I/O terminal board specifications

Power I/O terminals

Terminals	Function	Description
1L1, 3L2, 5L3	Mains Input	3ph Input voltage according Astat XT Main Voltage Option rating (Option 1, QT1_) 230-500VAC, +10%/-15% 50/60Hz (Option 2, QT2_) 460-600VAC, +10%/-15% 50/60Hz (Option 3, QT3_) 690VAC, +10%/-15% 50/60Hz
2T1, 4T2, 6T3	Output to motor	Power Output terminals to 3ph AC motor
A, B, C	By-pass	Bypass terminals for external by-pass contactor
G	Ground	ASTAT XT, ground connection

Control power supply

L, N	Control Supply	a110VAC or 220VAC, according ASTAT XT Control Voltage rating
F	Fan control	Cooling fan external control, together with jumper J1 Control Voltage & Fan consumption VA: QTx0008 to QTx0031: No fan. Total consumption: 150VA QTx0044 to QTx0072: Fan 35 VA. Total consumption 185VA QTx0085 to QTx0170: Fan 60 VA. Total consumption 210VA QTx0210 to QTx0390: Fans 105VA. Total consumption 255VA QTx0390 to QTx 1400A : Fans 150VA.Total consumption 300VA

Digital inputs

4	Stop	Dedicated input to Stop
5	Soft Stop	Dedicated input to Soft Stop
6	Start	Dedicated input to Start
7	Programmable Inputs	Programmable to functions Energy Saving, Slow Speed and Reset
8	Programmable Inputs	Programmable to functions Dual Set, Reverse and Reset
9	Common	Common terminal for digital inputs from 4, 5, 6, 7 and 8
		Operating Voltage of digital inputs from 4 to 9 Digital Input hardware is operated according either of below ordered voltage ratings (Option 1, standard) From 90 to 230VAC +10%, 50/60Hz (Option 2, Optional) 24VDC +10%/ -15%

Other inputs

19, 21	External fault	Requires a free voltage relay contact, to detect external fault
21	Neutral	This terminal may be connected to Mains Neutral when available
28, 29	Motor thermistor	PTC or NTC programmable input for motor thermistor protection The input can be enabled or disabled, and programmed at desired trip level resistance

Digital outputs

10, 11, 12	RUN	Run Relay with NO & NC dry contact. Programmable ON delay
13, 14, 15	FAULT	Fault to ON or Fault to OFF programmable function
16, 17, 18	EOR	End Of Ramp relay. Programmable ON delay
		Relay Outputs Ratings Max rating: 8A, 250VAC, 2000VA max

Analogue output

31, 32	Current output	Range 0 to 2xIn. Programmable 0-10VDC, 0-20mA or 4-20mA
30	Ground	Ground terminal for Analog Output

Communications

D+, D-, SG	RS485 terminals	RS485 Communication port, half duplex for ModBus protocol Baudrate 1200, 2400, 4800, 9600 BPS
D-9 connector	Profibus port	Optional Profibus Communications port
V+, CL, Dr, CH, V-	DeviceNet terminals	Optional Devicenet Communications port



Application wiring diagrams

Basic diagram without line contactor⁽¹⁾

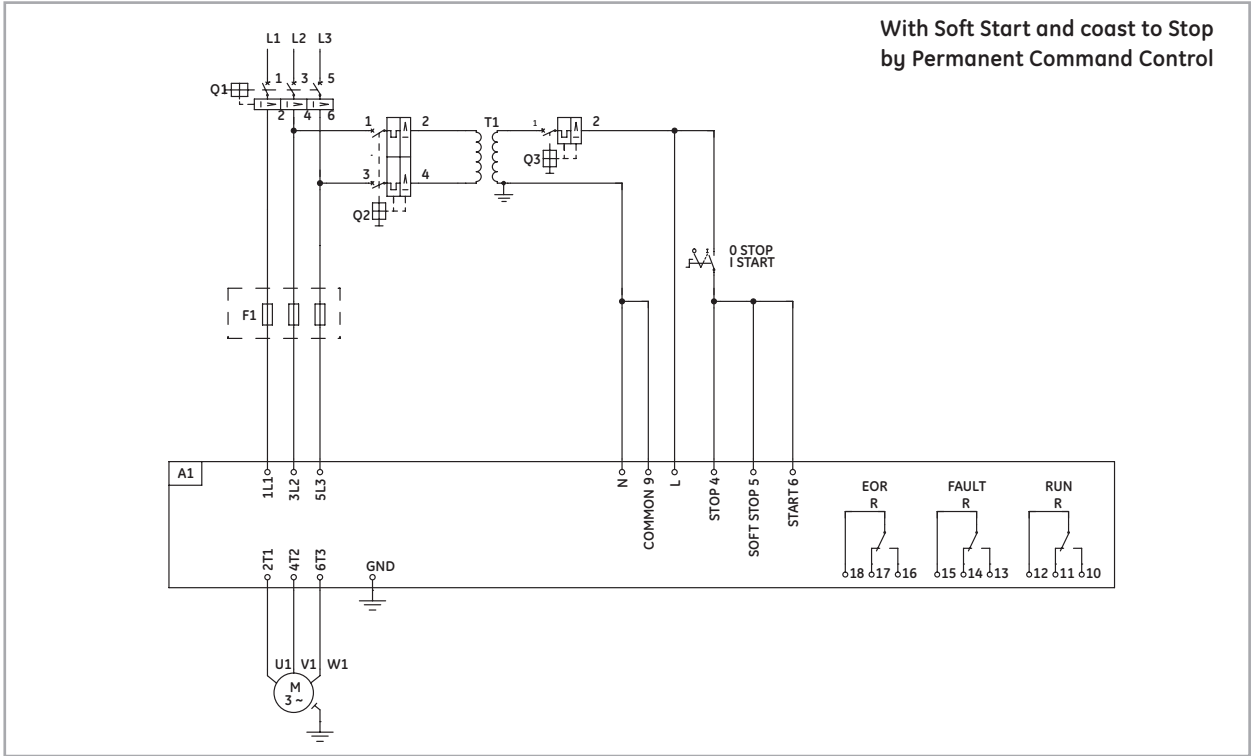

Basic diagram without line contactor⁽¹⁾

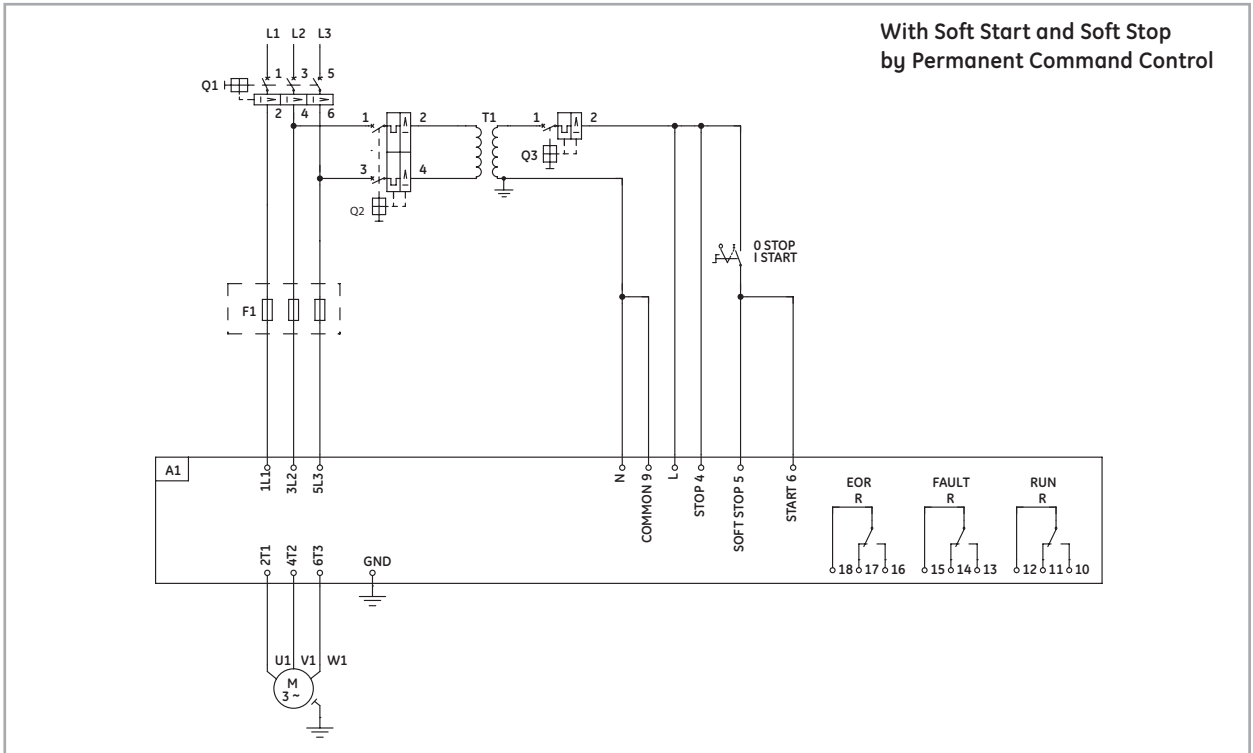

(1) Schemes are given for information purposes. Add additional emergency safety stop, if it is required for your application.

Remarks

1. Check coordination tables for proper selection of Breaker and Line contactor.
2. Control Voltage and Control Input voltage are from same source in above example. Please check manuals if you have different sources for Control Voltage and Control input Voltage.
3. Semiconductor Fuses "F" are only required for Type 2 coordination. Please check coordination tables
4. In spite of ASTAT XT can operate without line contactor, the use of a line contactor will increase the operation safety. Anyway provide a way to switch off the Breaker in case of an emergency.



Application wiring diagrams

Basic diagram without line contactor⁽¹⁾

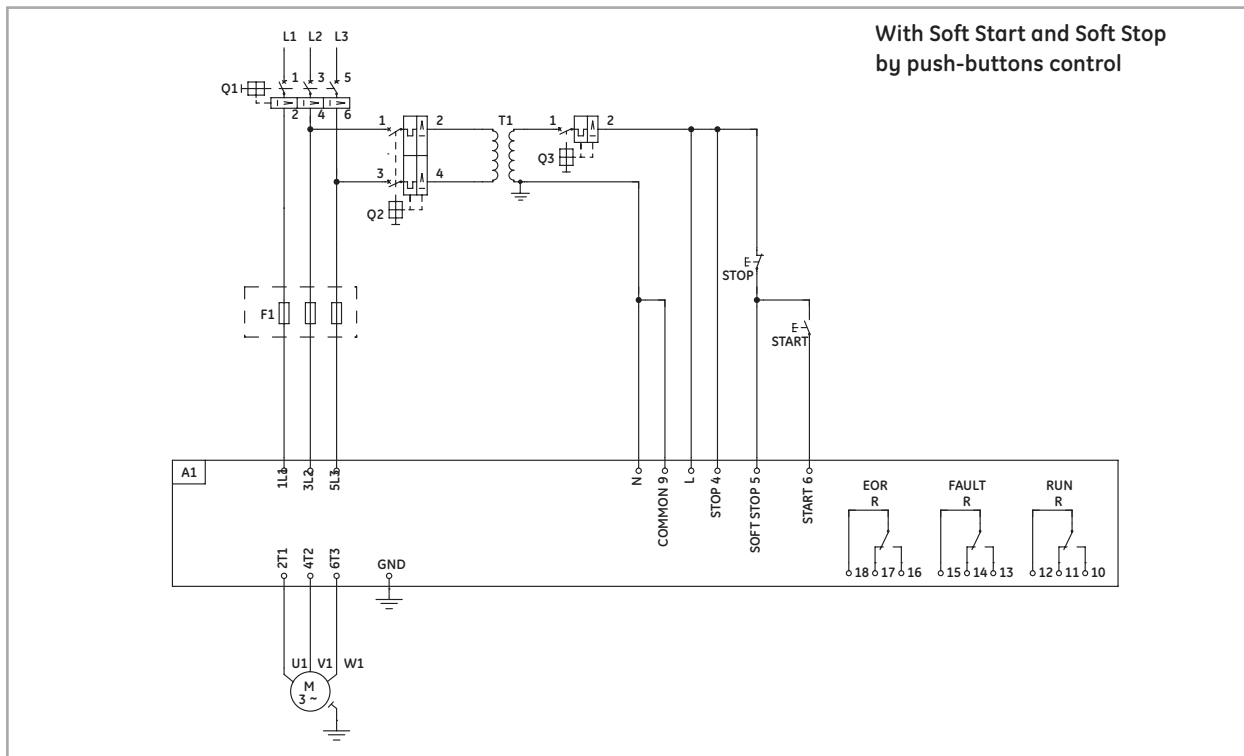

Basic diagram with line contactor⁽¹⁾

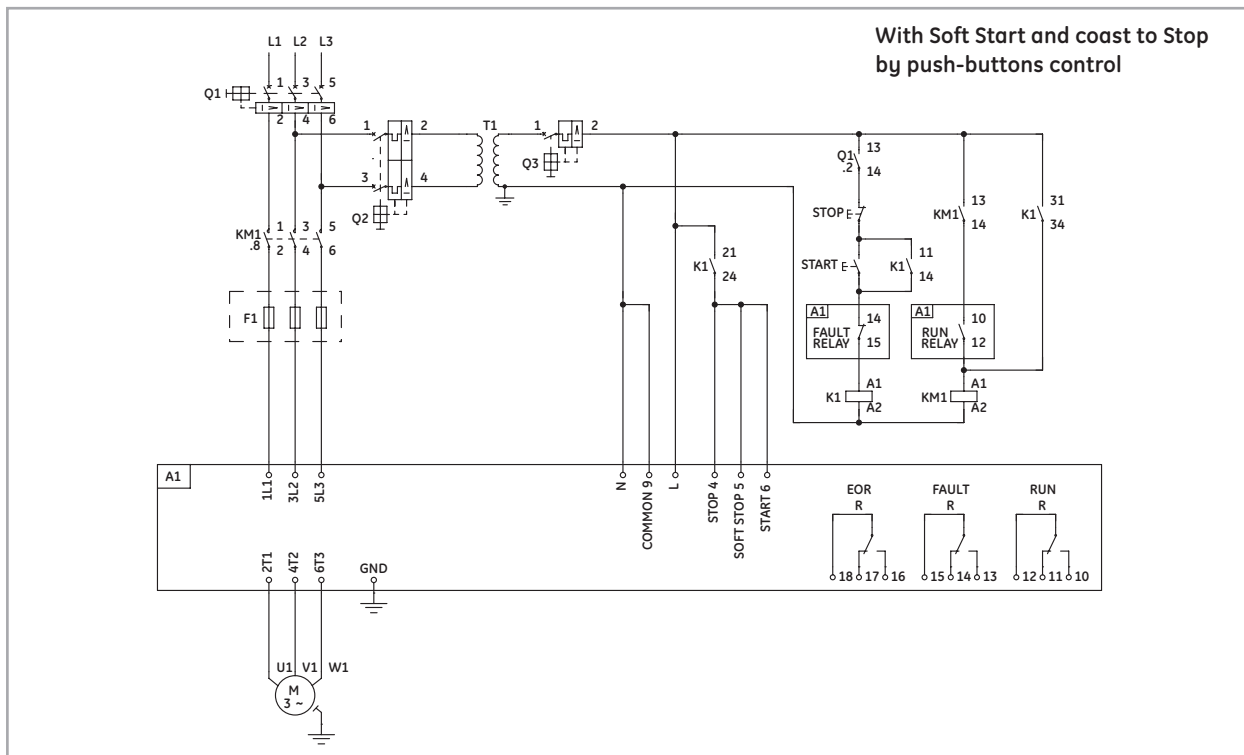

(1) Schemes are given for information purposes. Add additional emergency safety stop, if it is required for your application.

Remarks

1. Check coordination tables for proper selection of Breaker and Line contactor.
2. Control Voltage and Control Input voltage are from same source in above example. Please check manuals if you have different sources for Control Voltage and Control input Voltage.
3. Semiconductor Fuses "F" are only required for Type 2 coordination. Please check coordination tables
4. In spite of ASTAT XT can operate without line contactor, the use of a line contactor will increase the operation safety. Anyway provide a way to switch off the Breaker in case of an emergency.

Application wiring diagrams

Basic diagram with line contactor⁽¹⁾

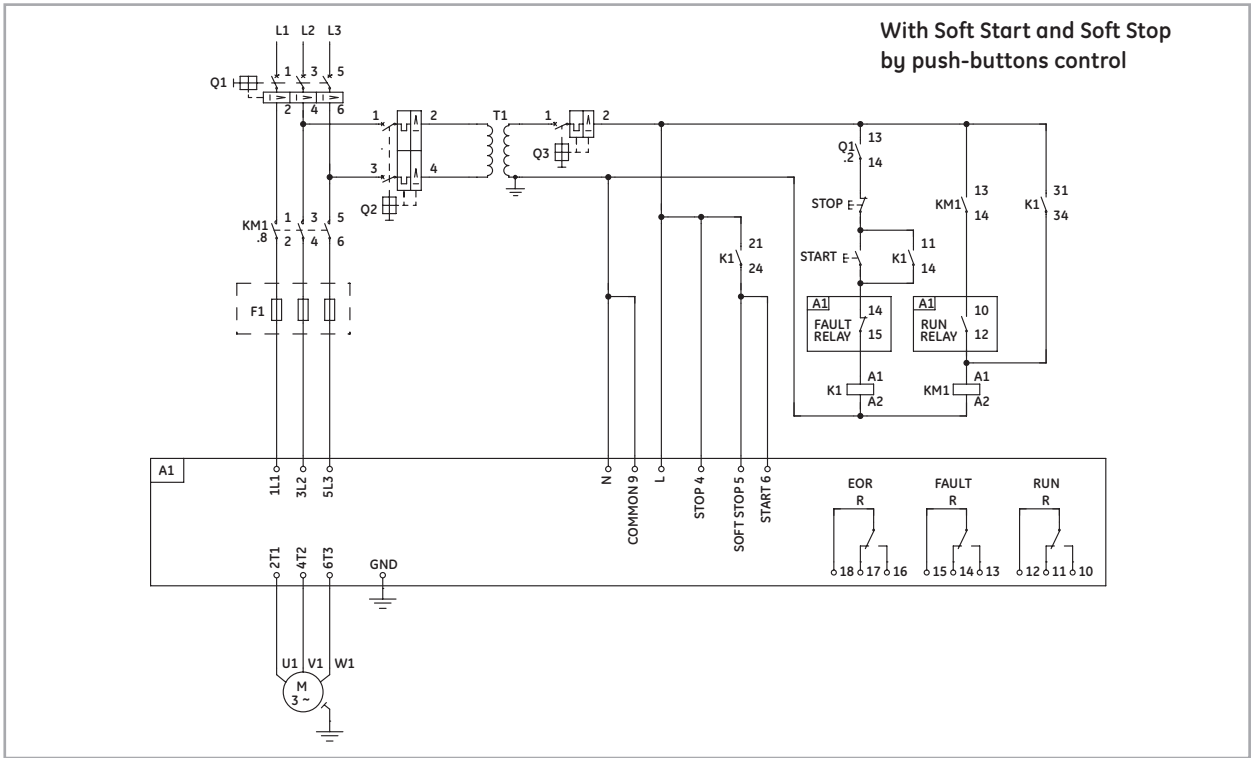

Basic diagram with line and bypass contactors⁽¹⁾

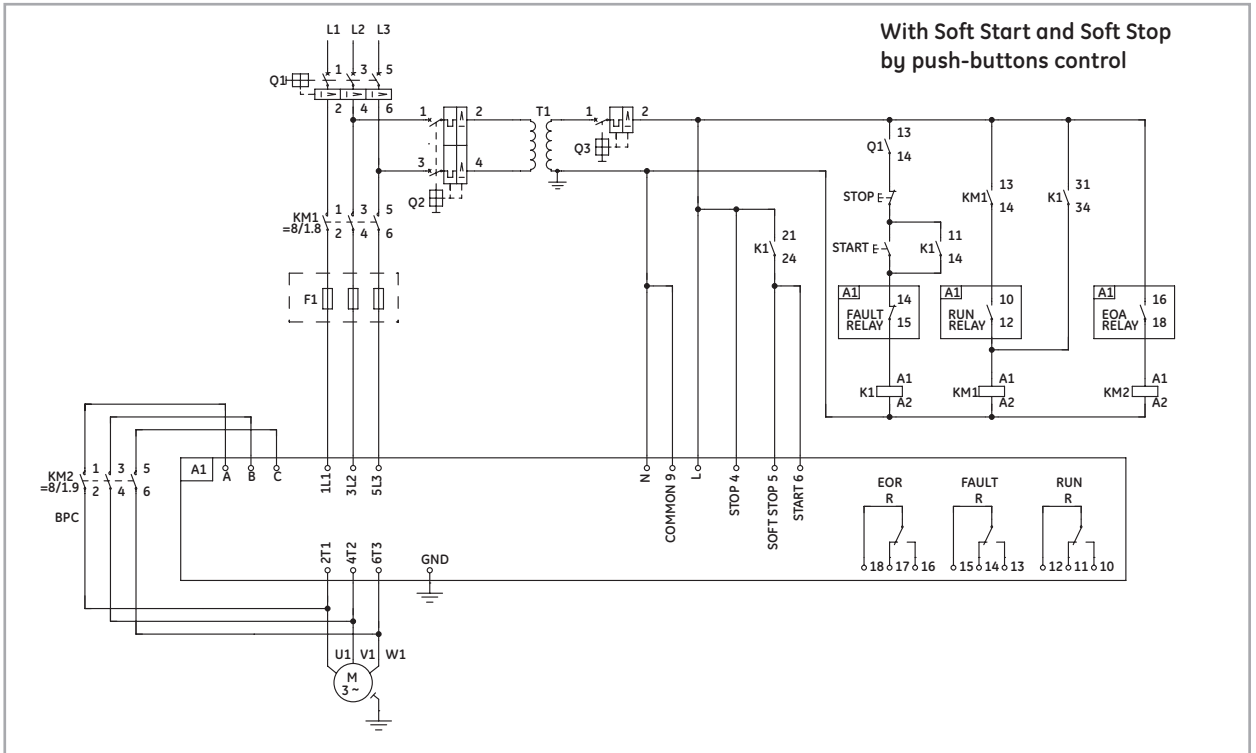

(1) Above schemes are given for information purposes. Add additional emergency safety stop, if it is required for your application.

Remarks

1. Check coordination tables for proper selection of Breaker and Line contactor.
2. Control Voltage and Control Input voltage are from same source in above example. Please check manuals if you have different sources for Control Voltage and Control input Voltage.
3. Semiconductor Fuses "F" are only required for Type 2 coordination. Please check coordination tables



Application wiring diagrams

Basic diagram in "Inside Delta" configuration with line and bypass contactors⁽¹⁾

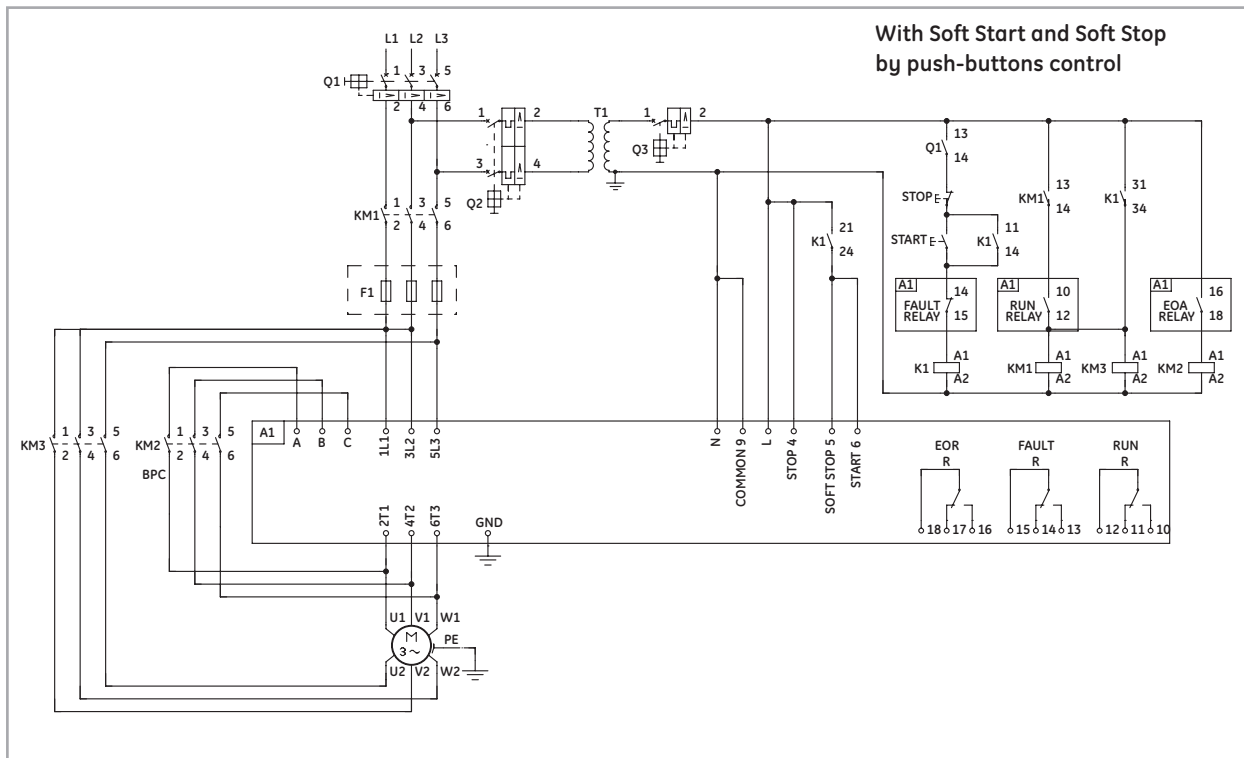

(1) Above schemes are given for information purposes. Add additional emergency safety stop, if it is required for your application.

Remarks

1. Check coordination tables for proper selection of Breaker and Line contactor.
2. Control Voltage and Control Input voltage are from same source in above example. Please check manuals if you have different sources for Control Voltage and Control input Voltage.
3. Semiconductor Fuses "F" are only required for Type 2 coordination. Please check coordination tables
4. Wrong connection of the motor, or the ASTAT-XT when it is Inside-delta connected may seriously damage the motor or the ASTAT-XT. Please check additional details given in the ASTAT XT's instruction manual.

Coordination Type 1

Combination with aM fuses - 415V

Soft starters

Main Voltage Up to 415VAC	ASTAT-XT type		aM fuses		Contactor Type	Short-circuit current	
	Rating (A)	Cat. No.		Rating (A)	CL/CK series	Iq (kA)	
	8	-	QT10008	-	16	CL00	80
	17	-	QT10017	-	20	CL02	80
	31	-	QT10031	-	35	CL04	80
	44	-	QT10044	-	50	CL06	80
	58	-	QT10058	-	80	CL07	80
	72	-	QT10072	-	100	CL08	80
	85	-	QT10085	-	125	CL09	80
	105	-	QT10105	-	160	CL10	80
	145	-	QT10145	-	200	CK75C	80
	170	-	QT10170	-	200	CK08C	80
	210	-	QT10210	-	250	CK09B	80
	310	-	QT10310	-	400	CK95B	80
	390	-	QT10390	-	500	CK10C	80
	460	-	QT10460	-	630	CK11C	80
	580	-	QT10580	-	800	CK12B	80
	650	-	QT10650	-	1000	CK13B	80
	950	-	QT10950	-	2x630	-	80
	1100	-	QT11100	-	2x800	-	80
	1400	-	QT11400	-	2x800	-	80

Combination with Record Plus MCCB'S - 415V

Main Voltage Up to 415VAC	ASTAT-XT type		Circuit Breaker		Contactor Type	Short-circuit current	
	Rating (A)	Cat. No.	Record Plus	Rating (A)	CL/CK series	Iq (kA)	
	8	-	QT10008	FD63	16	CL45	65
	17	-	QT10017	FD63	40	CL06	65
	31	-	QT10031	FD63	50	CL06	65
	44	-	QT10044	FD160	63	CL06	65
	58	-	QT10058	FD160	80	CL07	65
	72	-	QT10072	FD160	80	CL08	65
	85	-	QT10085	FE160	125	CL10	65
	105	-	QT10105	FE160	160	CL10	65
	145	-	QT10145	FE160	160	CK85B	65
	170	-	QT10170	FE250	160	CK08	65
	210	-	QT10210	FE250	160	CK85	65
	310	-	QT10310	FG400	400	CK10C	65
	390	-	QT10390	FG400	400	CK12B	65
	460	-	QT10460	FG630	630	CK12B	65
	580	-	QT10580	FG630	630	CK13B	65
	650	-	QT10650	FK1250	1000	CK13B	50
	950	-	QT10950	FK1250	1000	-	50
	1100	-	QT11100	FK1250	1250	-	50
	1400	-	QT11400	FK1600	1600	-	50

Combination with aM fuses - 500V

Main Voltage 500 VAC	ASTAT-XT type		aM fuses		Contactor Type	Short-circuit current	
	Rating (A)	Cat. No.		Rating (A)	CL/CK series	Iq (kA)	
	8	QT10008	QT20008	-	16	CL00	80
	17	QT10017	QT20017	-	20	CL02	80
	31	QT10031	QT20031	-	35	CL04	80
	44	QT10044	QT20044	-	50	CL06	80
	58	QT10058	QT20058	-	80	CL07	80
	72	QT10072	QT20072	-	100	CL08	80
	85	QT10085	QT20085	-	125	CL09	80
	105	QT10105	QT20105	-	160	CL10	80
	145	QT10145	QT20145	-	200	CK75C	80
	170	QT10170	QT20170	-	200	CK08C	80
	210	QT10210	QT20210	-	250	CK09B	80
	310	QT10310	QT20310	-	400	CK95B	80
	390	QT10390	QT20390	-	500	CK10C	80
	460	QT10460	QT20460	-	630	CK11C	80
	580	QT10580	QT20580	-	800	CK12B	80
	650/820	QT10650	QT20820	-	1000	CK13B	80
	950	QT10950	QT20950	-	2x630	-	80
	1100	QT11100	QT21100	-	2x800	-	80
	1400	QT11400	QT21400	-	2x800	-	80



Coordination Type 2

Combination with semiconductor fuses - 415V

Main Voltage Up to 415VAC	Rating (A)	ASTAT-XT type		Semiconductor fuses ⁽¹⁾	Contactor Type	Short-circuit current
		Cat. No.	Bussmann type	CL/CK series	Iq (kA)	
	8	-	QT10008	170M3808D	CL25	80
	17	-	QT10017	170M3810D	CL25	80
	31	-	QT10031	170M3813D	CL04	80
	44	-	QT10044	170M3814D	CL45	80
	58	-	QT10058	170M3814D	CL07	80
	72	-	QT10072	170M3815D	CL08	80
	85	-	QT10085	170M3816D	CL09	80
	105	-	QT10105	170M3817D	CL10	80
	145	-	QT10145	170M3817D	CK75C	80
	170	-	QT10170	170M3819D	CK08C	80
	210	-	QT10210	170M4864D	CK09B	80
	310	-	QT10310	170M4864D	CK95B	80
	390	-	QT10390	170M5814D	CK10C	80
	460	-	QT10460	170M5820D	CK11C	80
	580	-	QT10580	170M5816D	CK12B	50
	650	-	QT10650	2x170M5814D	CK13B	80
	950	-	QT10950	2x170M5816D	-	80
	1100	-	QT11100	2x170M6892D	-	80
	1400	-	QT11400	2x170M8555D	-	80

Combination with semiconductor fuses - 500V

Main Voltage 500 VAC	Rating (A)	ASTAT-XT type		Semiconductor fuses ⁽¹⁾	Contactor Type	Short-circuit current
		Cat. No.	Bussmann type	CL/CK series	Iq (kA)	
	8	QT10008	QT20008	170M3808D	CL25	80
	17	QT10017	QT20017	170M3810D	CL25	80
	31	QT10031	QT20031	170M3813D	CL04	80
	44	QT10044	QT20044	170M3814D	CL06	80
	58	QT10058	QT20058	170M3814D	CL07	80
	72	QT10072	QT20072	170M3815D	CL08	80
	85	QT10085	QT20085	170M3816D	CL09	80
	105	QT10105	QT20105	170M3817D	CL10	80
	145	QT10145	QT20145	170M3817D	CK75C	80
	170	QT10170	QT20170	170M3819D	CK08C	80
	210	QT10210	QT20210	170M4864D	CK09B	80
	310	QT10310	QT20310	170M4864D	CK10C	80
	390	QT10390	QT20390	170M5814D	CK10C	80
	460	QT10460	QT20460	170M5820D	CK11C	80
	580	QT10580	QT20580	170M5816D	CK12B	50
	650/820	QT10650	QT20820	2x170M5814D	CK13B	80
	950	QT10950	QT20950	2x170M5816D	-	80
	1100	QT11100	QT21100	2x170M6892D	-	80
	1400	QT11400	QT21400	2x170M8555D	-	80

Combination with semiconductor fuses - 690V

Main Voltage 690 VAC	Rating (A)	ASTAT-XT type		Semiconductor fuses ⁽¹⁾	Contactor Type	Short-circuit current
		Cat. No.	Bussmann type	CL/CK series	Iq (kA)	
	8	-	QT30008	170M3808D	CL25	50
	17	-	QT30017	170M3810D	CL25	50
	31	-	QT30031	170M3813D	CL06	50
	44	-	QT30044	170M3814D	CL06	50
	58	-	QT30058	170M3814D	CL07	50
	72	-	QT30072	170M3815D	CL08	50
	85	-	QT30085	170M3816D	CK75C	50
	105	-	QT30105	170M3817D	CK75C	50
	145	-	QT30145	170M3817D	CK08B	50
	170	-	QT30170	170M3819D	CK08B	50
	210	-	QT30210	170M4864D	CK08B	50
	310	-	QT30310	170M4864D	CK10C	50
	390	-	QT30390	170M5814D	CK10C	50
	460	-	QT30460	170M5820D	CK12B	50
	580	-	QT30580	170M5816D	CK12B	30
	650	-	QT30650	2x170M5814D	-	50
	950	-	QT30950	2x170M5816D	-	50
	1100	-	QT31100	2x170M6892D	-	50
	1400	-	QT31400	2x170M8555D	-	50

(1) Semiconductor Fuses must be always used for Type 2 coordination



Dimensions and weights

Cat. No.: QTx0008U_, QTx0017U_, QTx0031U_, QTx0044U_, QTx0058U_, QTx0072U_

Soft starters

Cat. No	Dimensions		Power terminal size (mm ²)			Weight Kg
	D1	D2	1L1, 3L2, 5L3	A, B, C	2T1, 4T2, 6T3	
QTx0008U	160	182.5	16	16	16	4.2
QTx0017U	160	182.5	16	16	16	4.2
QTx0031U	160	182.5	16	16	16	5.3
QTx0044U	207	229.5	16	16	35	6.7
QTx0058U	207	229.5	16	16	35	6.7
QTx0072U	207	229.5	35	35	35	6.7

UL Certified units

Cat. No.: QTx0085U_, QTx0105U_

Cat. No.	Weight
QTx0085U	15.2
QTx0105U	15.2

UL Certified units

Intro

A

B

C

D

E

F

G

H

I

J/X



Dimensions and weights

Cat. No.: QTx0145U_, QTx0170U_

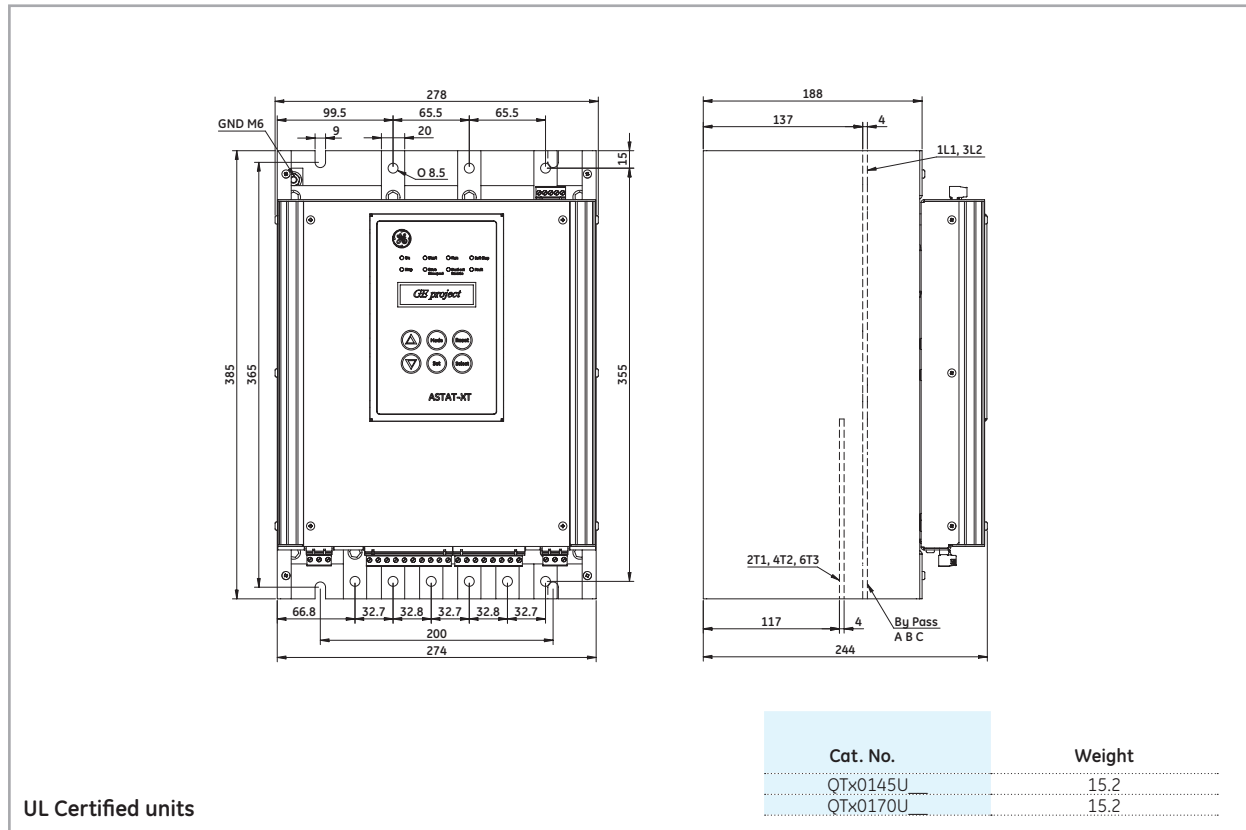

Cat. No.: QTx0210N_, QTx0310N_, QTx0390N_, QTx0460N_

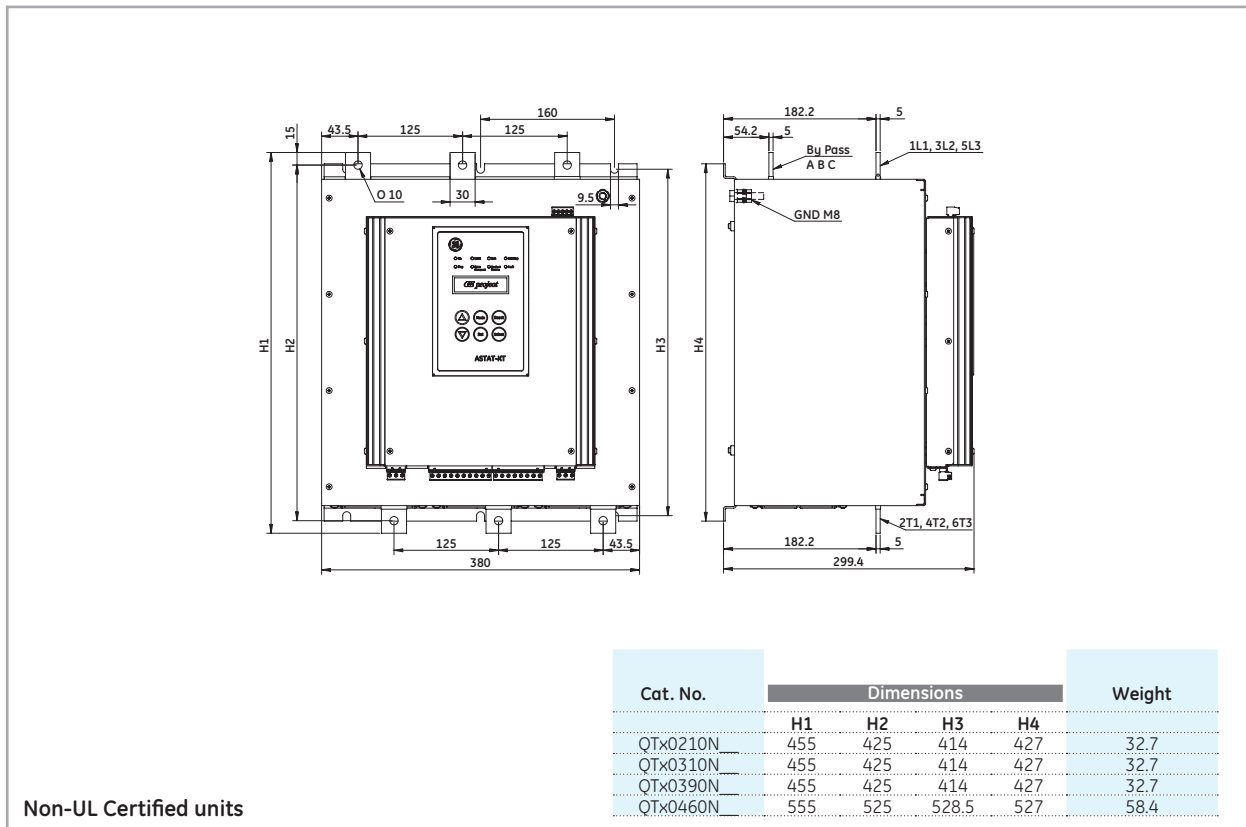

Dimensions and weights

Cat. No.: QTx0580N_

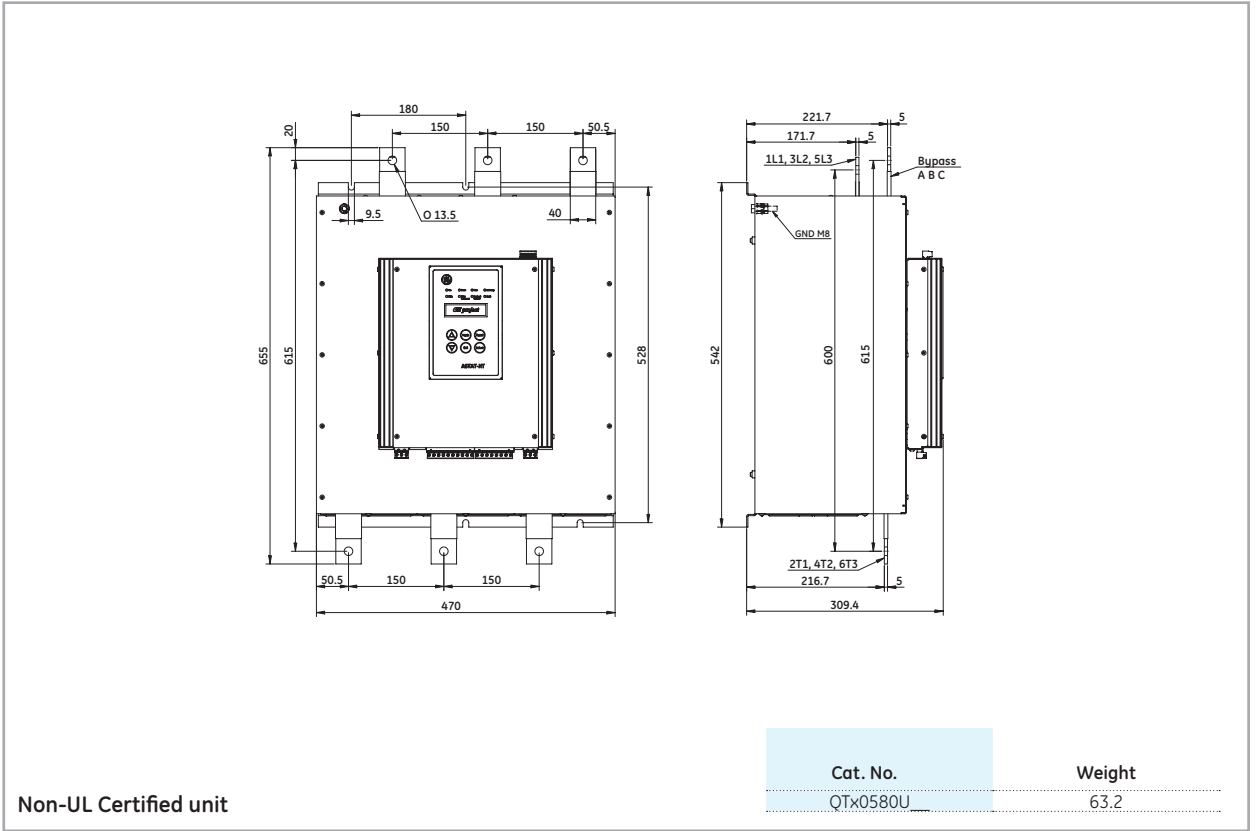

Cat. No.: QTx0650N_

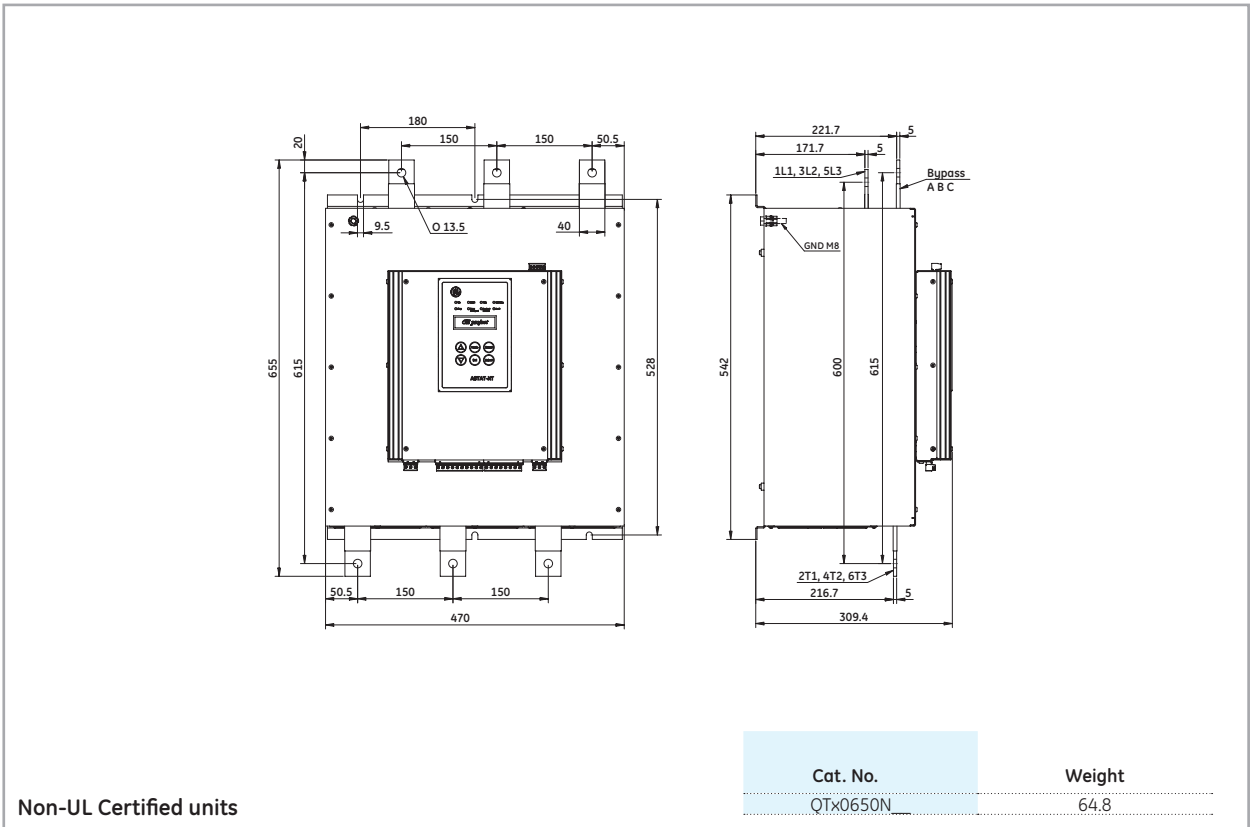

Soft starters

Intro

A

B

C

D

E

F

G

H

I

J/X



Dimensions and weights

Cat. No.: QTx0950N_

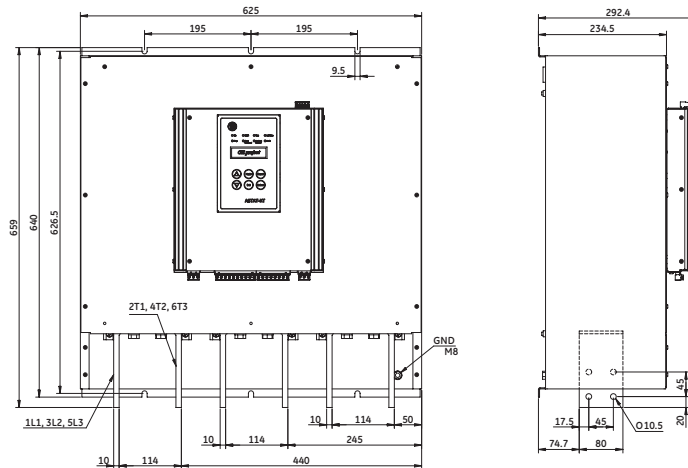

Remarks

1. This unit must be operated with a bypass contactor
 2. Add space for current transformers (supplied separately from the main unit) and bus bars for preparation for bypass
- Approximate current transformers dimensions: W=240mm, H=130mm, D=90mm

Non-UL Certified unit

Cat. No.

QTx0950N_

Weight

86.7

Cat. No.: QTx1100N_ , QTx1400N

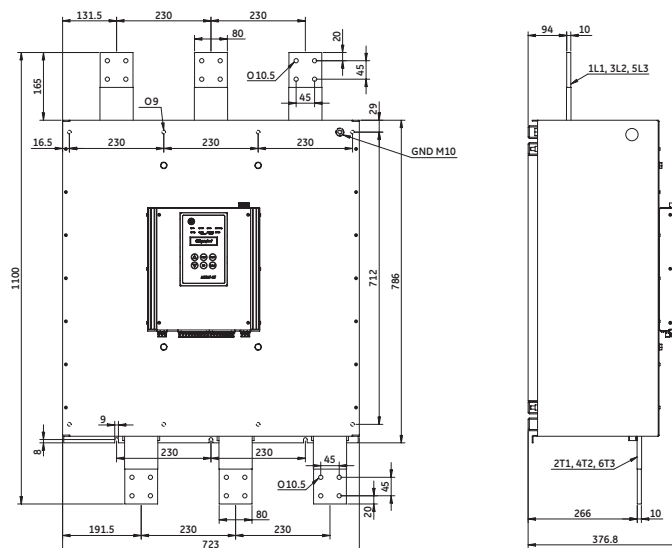

Remarks

1. Units must be operated with a bypass contactor
2. Add space for current transformers (Supplied separately from main unit) and bus bars for preparation for bypass

Approximate current transformers dimensions:
 W=240mm, H=130mm, D=90mm. (for 1100A unit, Cat Numbers QTx1100N_)
 W=270mm, H=155mm, D=90mm. (for 1400A unit, Cat Numbers QTx1400N_)

Non-UL Certified unit

Cat. No.

QTx1100N_

Weight

169.8

QTx1400N_

175.5

Dimensions and weights

Cat. No.: QTx0210U_, QTx0315U_, QTx0390U_

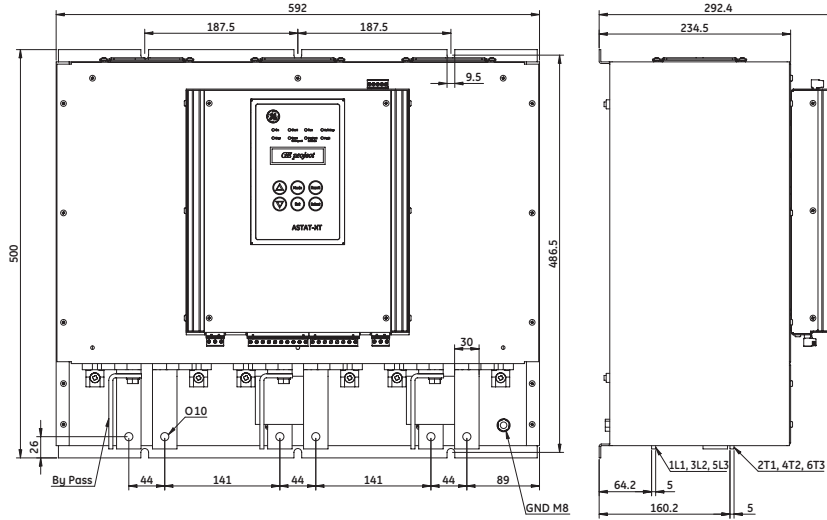

UL Certified unit

Cat. No.	Weight
QTx0210U	32.7
QTx0310U	32.7
QTx0390U	32.7

Cat. No.: QTx0460U_

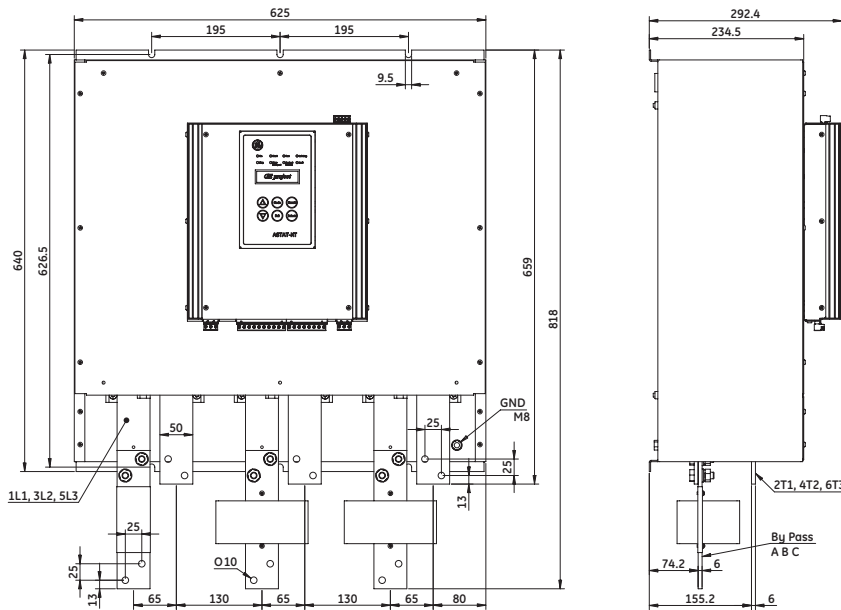

UL Certified unit

Cat. No.	Weight
QTx0460U	61.8



Dimensions and weights

Cat. No.: QTx0580U_, QTx0820U_

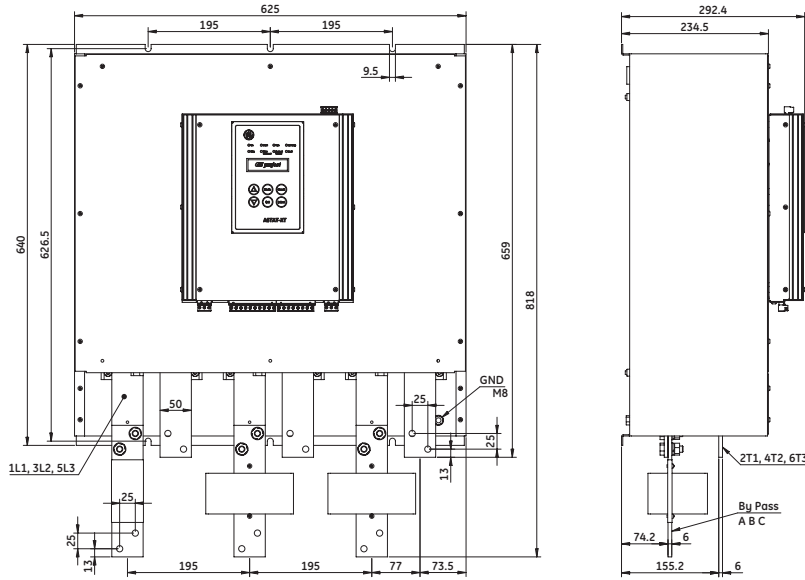

UL Certified unit

Cat. No.	Weight
QTx0580U_	69.5
QTx0820U_	69.5

