

SURION - Manual motor starter

Order codes

- C.2 **GPS1B** - Thermal and magnetic protection
- C.4 **GPS2B** - Thermal and magnetic protection
- C.6 **GPS1M** - Magnetic protection
- C.8 **GPS2M** - Magnetic protection
- C.10 Auxiliaries
- C.12 Accessories
- C.14 Fuseless starters and busbar adapter plates
- C.16 Enclosures

Technical data

- C.18 Technical performance
- C.22 Mounting possibilities of the auxiliaries
- C.24 Dimensions

POWER DEVICES

Contactors and overload relays

SURION

Manual Motor Starters and Coordination tables
see chapter D pages D.11-D.17

Auxiliary relays and contactors

Motor protection devices

SFK - Motor protection circuit breaker

- C.32 Order codes
- C.35 Terminal numbering
- C.36 Technical data
- C.37 Dimensions

Applications

Main switches

AUXILIARY DEVICES

Control and signalling units

Electronic relays and limit switches

POWER ELECTRONICS

Speed drive units

Soft starters

Lighting dimmer-stabilizer/Numerical index

Intro

A

B

C

D

E

F

G

H

I

J/X



Thermal and magnetic protection

GPS1B



Standards/Approvals

IEC 60947-1, 60947-2, 60947-4-1
 DIN VDE 0660T 100/101/102
 UL508/CSA - UL508/cULus
 Shipping approvals:



Characteristics

- Rocker and rotary handle operator
- Thermal and magnetic protection
- Standard and high breaking capacity
 $I_{cu} = 100kA \geq I_{cs} = 100\% I_{cu}$
 $I_{cu} < 100kA \geq I_{cs} \text{ min. } 75\% I_{cu}$
- Clear identification of the operation state (ON-OFF-tripped)
- Ambient temperature compensation
- Phase failure protection

Auxiliaries

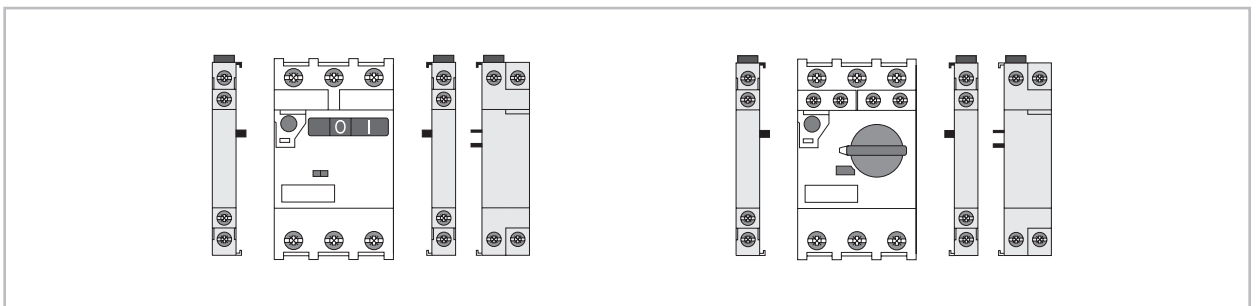

Technical performances

Rated current I_n	(A)	0.1-32
Rated operational current I_e (A)		0.1-32
Rated power at 400Vac	(kW)	0.02-15
Utilisation category		
IEC 60947-2 (circuit breaker)		A
IEC 60947-4-1 (MMS)		AC-3
Tripping class IEC 60947-4-1		10
Magnetic release $I_e \text{ max.}$	(A)	x13
Mechanical/electrical endurance		100,000

Accessories
 Auxiliaries ● pg. C.10
 Busbar system ● pg. C.13

Technical data ● pg. C.18
 Dimensions ● pg. C.24
 Fuseless starters ● pg. C.14
 Coordination tables ● pg. D.11



GPS1B - Standard breaking capacity

CLASS 10	Rated power 3 phase motors at 400Vac Pn	Rated current In (1)	Thermal current setting range	Instantaneous short-circuit release	Rated ultimate short-circuit breaking capacity at 400V Icu (kA)	Rated service short-circuit breaking capacity at 400V Ics (kA)	Cat. no.	Ref. no.	Pack.
	(kW)	(A)	(A)	(A)					
	0.02	0.16	0.10 - 0.16	2.1	100	100	GPS1BSAA	101211	5
	0.06	0.25	0.16 - 0.25	3.3	100	100	GPS1BSAB	101212	5
	0.09	0.4	0.25 - 0.40	5.2	100	100	GPS1BSAC	101213	5
	0.12/0.18	0.63	0.40 - 0.63	8.2	100	100	GPS1BSAD	101214	5
	0.25	1	0.63 - 1.00	13	100	100	GPS1BSAE	101215	5
	0.37/0.55	1.6	1.0 - 1.6	20.8	100	100	GPS1BSAF	101216	5
	0.75	2.5	1.6 - 2.5	32.5	100	100	GPS1BSAG	101217	5
	1.5	4	2.5 - 4.0	52	100	100	GPS1BSAH	101218	5
	2.2	6.3	4.0 - 6.3	81.9	100	100	GPS1BSAJ	101219	5
	3/4	10	6.3 - 10	130	100	100	GPS1BSAK	101220	5
	5.5	13	9 - 13	169	50	38	GPS1BSAL	101221	5
	7.5	16	11 - 16	208	25	19	GPS1BSAM	101222	5
	10	20	14 - 20	260	25	19	GPS1BSAN	101223	5
	11	25	19 - 25	325	25	19	GPS1BSAP	101224	5
	15	32	24 - 32	416	25	19	GPS1BSAR	101225	5



(1) Rated current: highest thermal current setting range value.

GPS1B - High breaking capacity.

CLASS 10	Rated power 3 phase motors at 400Vac Pn	Rated current In (1)	Thermal current setting range	Instantaneous short-circuit release	Rated ultimate short-circuit breaking capacity at 400V Icu (kA)	Rated service short-circuit breaking capacity at 400V Ics (kA)	Cat. no.	Ref. no.	Pack.
	(kW)	(A)	(A)	(A)					
	0.02	0.16	0.10 - 0.16	2.1	100	100	GPS1BHAA	101234	5
	0.06	0.25	0.16 - 0.25	3.3	100	100	GPS1BHAB	101235	5
	0.09	0.4	0.25 - 0.40	5.2	100	100	GPS1BHAC	101236	5
	0.12/0.18	0.63	0.40 - 0.63	8.2	100	100	GPS1BHAD	101237	5
	0.25	1	0.63 - 1.00	13	100	100	GPS1BHA E	101238	5
	0.37/0.55	1.6	1 - 1.6	20.8	100	100	GPS1BHAF	101239	5
	0.75	2.5	1.6 - 2.5	32.5	100	100	GPS1BHAG	101240	5
	1.5	4	2.5 - 4.0	52	100	100	GPS1BHAH	101241	5
	2.2	6.3	4.0 - 6.3	81.9	100	100	GPS1BHAJ	101242	5
	3/4	10	6.3 - 10	130	100	100	GPS1BHAK	101243	5
	5.5	13	9 - 13	169	100	100	GPS1BHAL	101244	5
	7.5	16	11 - 16	208	50	38	GPS1BHAM	101245	5
	10	20	14 - 20	260	50	38	GPS1BHAN	101246	5
	11	25	19 - 25	325	50	38	GPS1BHAP	101247	5
	15	32	24 - 32	416	50	38	GPS1BHAR	101248	5



(1) Rated current: highest thermal current setting range value.

Order codes

Intro

A

B

C

D

E

F

G

H

I

J/X



Thermal and magnetic protection

GPS2B

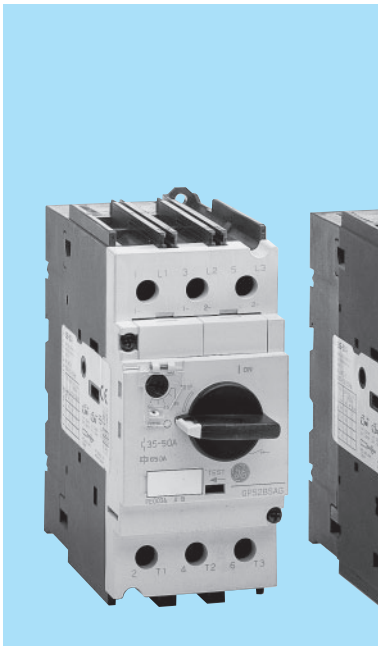

Standards/Approvals

IEC 60947-1, 60947-2, 60947-4-1
 DIN VDE 0660T 100/101/102
 UL508/CSA - UL508/cULus
 Shipping approvals:



RINA



Bureau
Veritas



Lloyd's Register
Germanischer Lloyd



Characteristics

- Rotary handle operator
- Thermal and magnetic protection
- Standard and high breaking capacity
 $I_{cu} = 100kA \geq I_{cs} = 100\% I_{cu}$
 $I_{cu} < 100kA \geq I_{cs} \text{ min. } 75\% I_{cu}$
- Clear identification of the operation state (ON-OFF-tripped)
- Ambient temperature compensation
- Phase failure protection

Auxiliaries

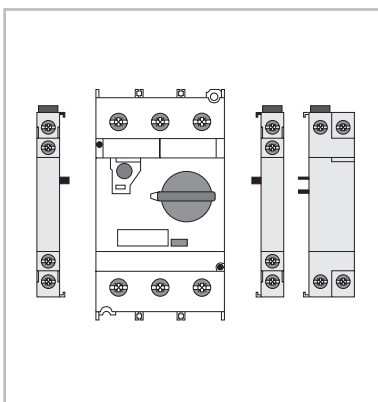

Technical performances

Rated current I_n	(A)	10-63
Rated operational current I_e	(A)	10-63
Rated power at 400Vac	(kW)	4-30
Utilisation category		
IEC 60947-2 (circuit breaker)		A
IEC 60947-4-1 (MMS)		AC-3
Tripping class IEC 60947-4-1		10
Magnetic release $I_e \text{ max.}$	(A)	x13
Mechanical/electrical endurance		50,000/25,000

Accessories

- Auxiliaries ● pg. C.10
- Busbar system ● pg. C.13

- Technical data ● pg. C.18
- Dimensions ● pg. C.24
- Fuseless starters ● pg. C.14
- Coordination tables ● pg. D.11

GPS2B - Standard breaking capacity

CLASS 10	Rated power 3 phase motors at 400Vac Pn	Rated current In (1)	Thermal current setting range	Instantaneous short-circuit release	Rated ultimate short-circuit breaking capacity at 400V Icu (kA)	Rated service short-circuit breaking capacity at 400V Ics (kA)	Cat. no.	Ref. no.	Pack.
	(kW)	(A)	(A)	(A)					
		3/4	10	6.3 - 10	130	100	100	GPS2BSAK	101226
	5.5	13	9 - 13	169	50	38	GPS2BSAL	107119	1
	7.5	16	11 - 16	208	25	19	GPS2BSAM	101227	1
	10	20	14 - 20	260	25	19	GPS2BSAN	101228	1
	11	25	19 - 25	325	25	19	GPS2BSAP	101229	1
	15	32	24 - 32	416	25	19	GPS2BSAR	101230	1
	18.5	40	28 - 40	520	25	19	GPS2BSAS	101231	1
	22	50	35 - 50	650	25	19	GPS2BSAT	101232	1
	30	63	45 - 63	819	25	19	GPS2BSAU	101233	1

(1) Rated current: highest thermal current setting range value.

GPS2B - High breaking capacity

CLASS 10	Rated power 3 phase motors at 400Vac Pn	Rated current In (1)	Thermal current setting range	Instantaneous short-circuit release	Short-circuit breaking capacity at 400V Icu (kA)	Short-circuit breaking capacity at 400V Ics (kA)	Cat. no.	Ref. no.	Pack.
	(kW)	(A)	(A)	(A)					
		3/4	10	6.3 - 10	130	100	100	GPS2BHAK	101249
	5.5	13	9 - 13	169	100	100	GPS2BHAL	107120	1
	7.5	16	11 - 16	208	50	38	GPS2BHAM	101250	1
	10	20	14 - 20	260	50	38	GPS2BHAN	101251	1
	11	25	19 - 25	325	50	38	GPS2BHAP	101252	1
	15	32	24 - 32	416	50	38	GPS2BHAR	101253	1
	18.5	40	28 - 40	520	50	38	GPS2BHAS	101254	1
	22	50	35 - 50	650	50	38	GPS2BHAT	101255	1
	30	63	45 - 63	819	50	38	GPS2BHAU	101256	1

(1) Rated current: highest thermal current setting range value.

Order codes

Intro

A

B

C

D

E

F

G

H

I

J/X



Magnetic protection

GPS1M



Standards/Approvals

IEC 60947-1, 60947-2, 60947-4-1
 DIN VDE 0660T 100/101/102
 UL508/CSA - UL508/cULus
 Shipping approvals:



RINA



Bureau Veritas



Lloyd's Register
 Germanischer Lloyd



cULus



CE

Characteristics

- Short-circuit protection for starters
- Rocker and rotary handle operator
- Magnetic protection
- Standard and high breaking capacity
 $I_{cu} = 100kA \geq I_{cs} = 100\% I_{cu}$
 $I_{cu} < 100kA \geq I_{cs} \text{ min. } 75\% I_{cu}$
- Clear identification of the operation state (ON-OFF-tripped)

Auxiliaries

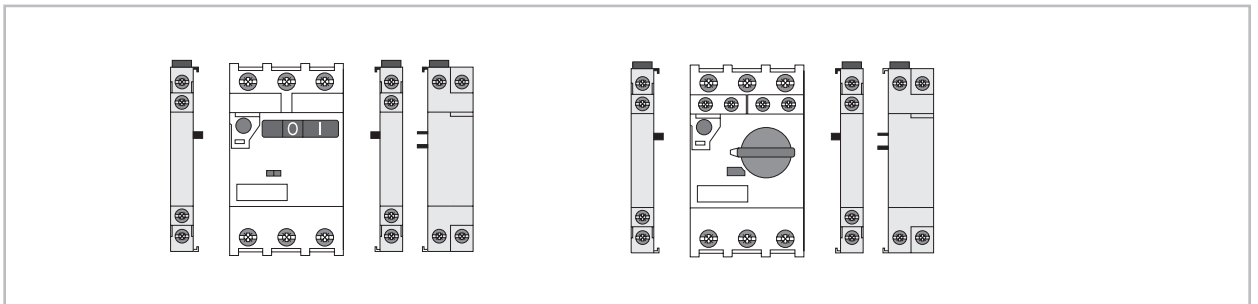

Accessories

- Auxiliaries ● pg. C.10
- Busbar system ● pg. C.13

- Technical data ● pg. C.18
- Dimensions ● pg. C.24
- Fuseless starters ● pg. C.14
- Coordination tables ● pg. D.11

Technical performances

Rated current I_n	(A) 0.1-32
Rated operational current I_e	(A) 0.1-32
Utilisation category	A
IEC 60947-2 (circuit breaker)	
Magnetic release $I_e \text{ max.}$	(A) x13
Mechanical/electrical endurance	100.000



GPS1M - Standard breaking capacity



Rated power 3 phase motors at 400Vac Pn	Rated current In	Thermal current setting range (1)	Instantaneous short-circuit release	Rated ultimate short-circuit breaking capacity at 400V Icu (kA)	Rated service short-circuit breaking capacity at 400V Ics (kA)	Cat. no.	Ref. no.	Pack.
(kW)	(A)	(A)	(A)					
0.02	0.16	-	2.1	100	100	GPS1MSAA	101257	5
0.06	0.25	-	3.3	100	100	GPS1MSAB	101258	5
0.09	0.4	-	5.2	100	100	GPS1MSAC	101259	5
0.12/0.18	0.63	-	8.2	100	100	GPS1MSAD	101260	5
0.25	1	-	13	100	100	GPS1MSAE	101261	5
0.37/0.55	1.6	-	20.8	100	100	GPS1MSAF	101262	5
0.75	2.5	-	32.5	100	100	GPS1MSAG	101263	5
1.5	4	-	52	100	100	GPS1MSAH	101264	5
2.2	6.3	-	81.9	100	100	GPS1MSAJ	101265	5
3/4	10	-	130	100	100	GPS1MSAK	101266	5
5.5	13	-	169	50	38	GPS1MSAL	101267	5
7.5	16	-	208	25	19	GPS1MSAM	101268	5
10	20	-	260	25	19	GPS1MSAN	101269	5
11	25	-	325	25	19	GPS1MSAP	101270	5
15	32	-	416	25	19	GPS1MSAR	101271	5

(1) Select appropriate thermal overload relay for the starter. See chapter A pages A.70 - A.75.

GPS1M - High breaking capacity



Rated power 3 phase motors at 400Vac Pn	Rated current In	Thermal current setting range (1)	Instantaneous short-circuit release	Rated ultimate short-circuit breaking capacity at 400V Icu (kA)	Rated service short-circuit breaking capacity at 400V Ics (kA)	Cat. no.	Ref. no.	Pack.
(kW)	(A)	(A)	(A)					
0.02	0.16	-	2.1	100	100	GPS1MHAA	101280	5
0.06	0.25	-	3.3	100	100	GPS1MHAB	101281	5
0.09	0.4	-	5.2	100	100	GPS1MHAC	101282	5
0.12/0.18	0.63	-	8.2	100	100	GPS1MHAD	101283	5
0.25	1	-	13	100	100	GPS1MHAE	101284	5
0.37/0.55	1.6	-	20.8	100	100	GPS1MHAF	101285	5
0.75	2.5	-	32.5	100	100	GPS1MHAG	101286	5
1.5	4	-	52	100	100	GPS1MHAH	101287	5
2.2	6.3	-	81.9	100	100	GPS1MHAJ	101288	5
3/4	10	-	130	100	100	GPS1MHAJ	101288	5
5.5	13	-	169	100	100	GPS1MHAK	101289	5
7.5	16	-	208	50	38	GPS1MHAL	101290	5
10	20	-	260	50	38	GPS1MHAM	101291	5
11	25	-	325	50	38	GPS1MHAN	101292	5
15	32	-	416	50	38	GPS1MHAP	101293	5
						GPS1MHAR	101294	5

(1) Select appropriate thermal overload relay for the starter. See chapter A pages A.70 - A.75.

Order codes

Intro

A

B

C

D

E

F

G

H

I

J/X



Magnetic protection

GPS2M



Standards/Approvals

IEC 60947-1, 60947-2, 60947-4-1
 DIN VDE 0660T 100/101/102
 UL508/CSA - UL508/cULus
 Shipping approvals:



RINA



Bureau Veritas



Lloyd's Register
 Germanischer Lloyd



CE

Characteristics

- Short-circuit protection for starters
- Rotary handle operator
- Magnetic protection
- Standard and high breaking capacity
 - $I_{cu} = 100kA \geq I_{cs} = 100\% I_{cu}$
 - $I_{cu} < 100kA \geq I_{cs} \text{ min. } 75\% I_{cu}$
- Clear identification of the operation state (ON-OFF-tripped)

Auxiliaries

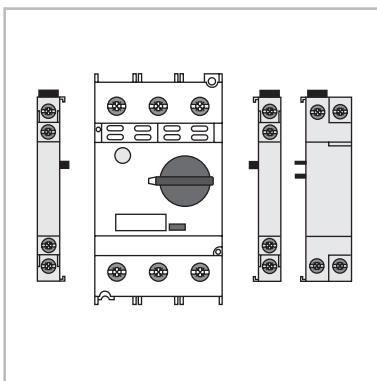

Technical performances

Rated current I_n	(A) 10-63
Rated operational current I_e	(A) 10-63
Utilisation category	A
IEC 60947-2 (circuit breaker)	
Magnetic release $I_e \text{ max.}$	(A) x13
Mechanical/electrical endurance	50,000/25,000

Accessories

- Auxiliaries ● pg. C.10
- Busbar system ● pg. C.13

- Technical data ● pg. C.18
- Dimensions ● pg. C.24
- Fuseless starters ● pg. C.14
- Coordination tables ● pg. D.11



GPS2M - Standard breaking capacity



Rated power 3 phase motors at 400Vac Pn	Rated current In	Thermal current setting range (1)	Instantaneous short-circuit release	Rated ultimate short-circuit breaking capacity at 400V Icu (kA)	Rated service short-circuit breaking capacity at 400V Ics (kA)	Cat. no.	Ref. no.	Pack.
(kW)	(A)	(A)	(A)					
4	10	-	130	100	100	GPS2MSAK	101272	1
5.5	13	-	169	50	38	GPS2MSAL	107121	1
7.5	16	-	208	25	19	GPS2MSAM	101273	1
10	20	-	260	25	19	GPS2MSAN	101274	1
11	25	-	325	25	19	GPS2MSAP	101275	1
15	32	-	416	25	19	GPS2MSAR	101276	1
18.5	40	-	520	25	19	GPS2MSAS	101277	1
22	50	-	650	25	19	GPS2MSAT	101278	1
30	63	-	819	25	19	GPS2MSAU	101279	1

(1) Select appropriate thermal overload relay for the starter. See chapter A pages A.72 - A.75.

GPS2M - High breaking capacity



Rated power 3 phase motors at 400Vac Pn	Rated current In	Thermal current setting range (1)	Instantaneous short-circuit release	Rated ultimate short-circuit breaking capacity at 400V Icu (kA)	Rated service short-circuit breaking capacity at 400V Ics (kA)	Cat. no.	Ref. no.	Pack.
(kW)	(A)	(A)	(A)					
4	10	-	130	100	100	GPS2MHAK	101295	1
5.5	13	-	169	100	100	GPS2MHAL	107122	1
7.5	16	-	208	50	38	GPS2MHAM	101296	1
10	20	-	260	50	38	GPS2MHAN	101297	1
11	25	-	325	50	38	GPS2MHAP	101298	1
15	32	-	416	50	38	GPS2MHAR	101299	1
18.5	40	-	520	50	38	GPS2MHAS	101300	1
22	50	-	650	50	38	GPS2MHAT	101301	1
30	63	-	819	50	38	GPS2MHAU	101302	1

(1) Select appropriate thermal overload relay for the starter. See chapter A pages A.71 - A.75.

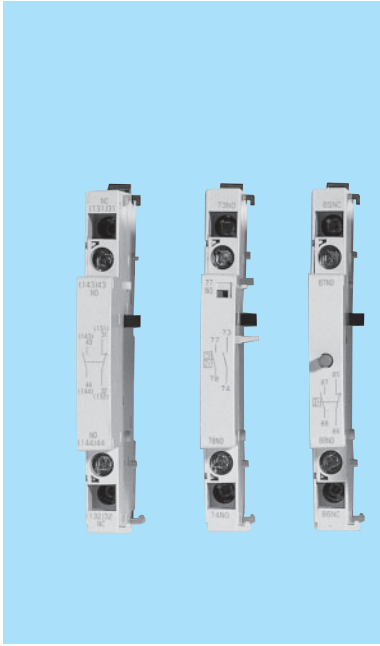

Auxiliaries

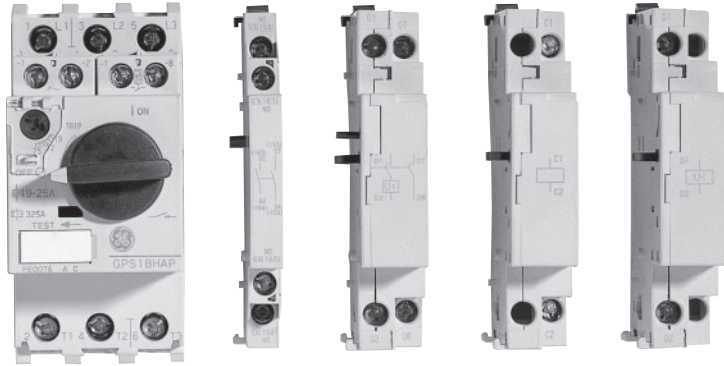

Standards/Approvals

IEC 60947-1, 60947-2, 60947-4-1
 DIN VDE 0660T 100/101/102
 UL508/CSA - UL508/cULus
 Shipping approvals:



RINA



Bureau Veritas



Lloyd's Register
 Germanischer Lloyd



cULus



CE

Product range

- Auxiliary contacts (frontal & lateral)
- Alarm contact block
- Auxiliary and alarm contact block
- Short-circuit alarm contact block
- Shunt trip
- Undervoltage release
- Undervoltage release with 2NO early make contacts
- External handle operator
- Terminal protector
- Busbar system

Auxiliaries

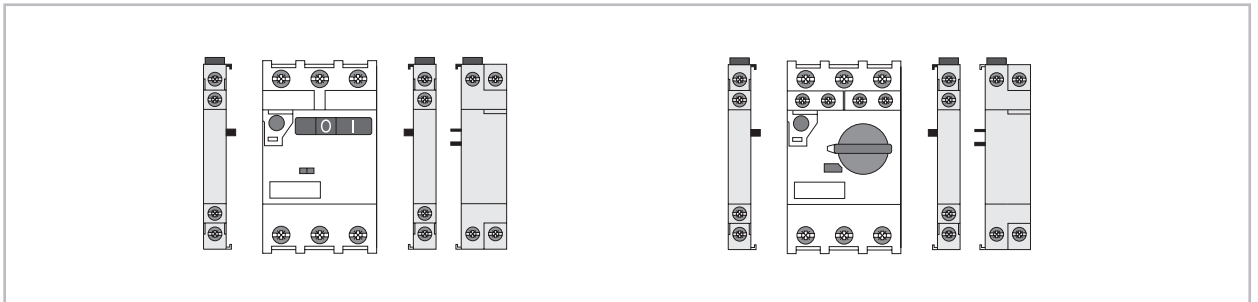

Technical performances

- All auxiliaries can be mounted and changed easily, without any tools
- Both frames GPS1 and GPS2 uses same auxiliaries
- All terminals are capable for 2 cables (0.5mm² - 2.5mm²)
- Side auxiliary contacts are rated to A600, P300 duty
- Frontal auxiliary contacts are rated to B300, Q300 duty
- Minimum operational contact 5mA, 17Vdc
- All terminal screwhead are Pozidriv 2 and slotted combination

Technical data ● pg. C.18
 Dimensions ● pg. C.24
 Fuseless starters ● pg. C.14
 Coordination tables ● pg. D.11

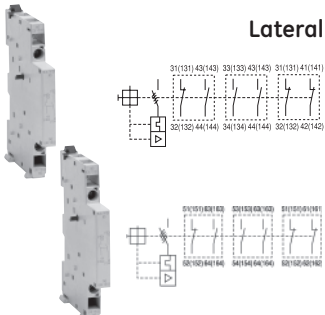

Auxiliary contact blocks

	Description	For use with	Type	Cat. no.	Ref. no.	Pack.
Frontal 	Maximum 2 auxiliary contact blocks per manual motor starter	GPS1... and GPS2...	1 NO	GPAC10FBA	101303	10
		GPS1... and GPS2...	1 NC	GPAC01FBA	101304	10
Lateral 	Two contacts Side mounting on the left	GPS1... and GPS2...	1 NO + 1 NC	GPAC11LLA	101305	10
		GPS1... and GPS2...	2 NO	GPAC20LLA	101306	10
		GPS1... and GPS2...	2 NC	GPAC02LLA	101307	10
	Two contacts Side mounting on the right	GPS1... and GPS2...	1 NO + 1 NC	GPAC11LRA	101308	10
		GPS1... and GPS2...	2 NO	GPAC20LRA	101309	10
		GPS1... and GPS2...	2 NC	GPAC02LRA	101310	10

Alarm contact block

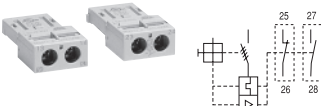
	Description	For use with	Type	Cat. no.	Ref. no.	Pack.
	Frontal mounting on the right Single contact	GPS1... and GPS2...	1 NO	GPAL10FRA	101311	10
		GPS1... and GPS2...	1 NC	GPAL01FRA	101312	10

Auxiliary / alarm contact block

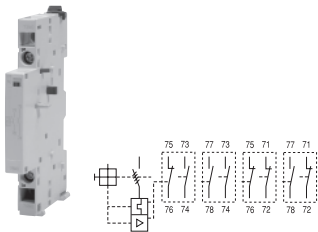
	Description	For use with	Type	Cat. no.	Ref. no.	Pack.
	Side mounting on the left (front alarm contact block can not be used at the same time)	GPS1... and GPS2...	1 NO(Alarm)+1 NO(Aux)	GPAD1010LLA	101313	10
		GPS1... and GPS2...	1 NO(Alarm)+1 NC(Aux)	GPAD1001LLA	101314	10
		GPS1... and GPS2...	1 NC(Alarm)+1 NO(Aux)	GPAD0110LLA	101315	10
		GPS1... and GPS2...	1 NC(Alarm)+1 NC(Aux)	GPAD0101LLA	101316	10
		Two contacts	GPS1... and GPS2...	1 NC(Alarm)+1 NC(Aux)	GPAD0101LLA	101316

Short-circuit alarm contact block

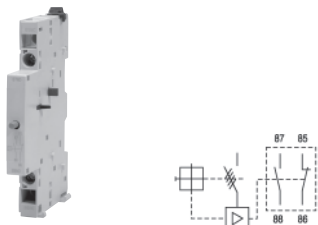
	Description	For use with	Type	Cat. no.	Ref. no.	Pack.
	Side mounting on the left Two contacts NO + NC Mechanical indication marking	GPS1... and GPS2...	1 NO + 1 NC	GPAE11LLA	101317	10

Order codes

Intro

A

B

C

D

E

F

G

H

I

J/X



Shunt trip device

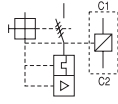

Description	For use with	Coil voltage	Cat. no.	Ref. no.	Pack.
Side mounting on the right Can not be used together with the undervoltage trip device	GPS1... and GPS2...	24V 50/60Hz	GPASLRAA1	101318	5
	GPS1... and GPS2...	48V 60Hz	GPASLRAAF	101319	5
	GPS1... and GPS2...	48V 50Hz / 60V 60Hz	GPASLRAAG	101320	5
	GPS1... and GPS2...	110/127V 50Hz / 120V 60Hz	GPASLRAAJ	101321	5
	GPS1... and GPS2...	208V 60Hz	GPASLRAAM	101322	5
	GPS1... and GPS2...	220/230V 50Hz / 240/260V 60Hz	GPASLRAAN	101323	5
	GPS1... and GPS2...	240V 50Hz / 277V 60Hz	GPASLRAAR	101324	5
	GPS1... and GPS2...	380/400V 50Hz	GPASLRAAU	101325	5
	GPS1... and GPS2...	415/440V 50Hz / 460/480V 60Hz	GPASLRAAW	101326	5
	GPS1... and GPS2...	500V 50Hz / 600V 60Hz	GPASLRAAY	101327	5
	GPS1... and GPS2...	24 to 60Vdc	GPASLRADD	101328	5
	GPS1... and GPS2...	110 to 240Vdc	GPASLRADJ	101329	5
	GPS1... and GPS2...	100V 50/60Hz	GPASLRAA11	101194	5

Undervoltage trip device

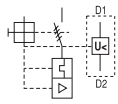

Description	For use with	Coil voltage	Cat. no.	Ref. no.	Pack.
Side mounting on the right Can not be used together with the shunt trip device	GPS1... and GPS2...	24V 50Hz	GPAULRAAD	101330	10
	GPS1... and GPS2...	24V 60Hz	GPAULRAAC	101331	10
	GPS1... and GPS2...	48V 50Hz	GPAULRAAG	101332	10
	GPS1... and GPS2...	48V 60Hz	GPAULRAAF	101333	10
	GPS1... and GPS2...	110/127V 50Hz / 120V 60Hz	GPAULRAAJ	101334	10
	GPS1... and GPS2...	208V 60Hz	GPAULRAAM	101335	10
	GPS1... and GPS2...	220/230V 50Hz / 240/260V 60Hz	GPAULRAAN	101336	10
	GPS1... and GPS2...	240V 50Hz / 277V 60Hz	GPAULRAAR	101337	10
	GPS1... and GPS2...	380/400V 50Hz	GPAULRAAU	101338	10
	GPS1... and GPS2...	415/440V 50Hz / 460/480V 60Hz	GPAULRAAW	101339	10
	GPS1... and GPS2...	500V 50Hz / 600V 60Hz	GPAULRAAY	101340	10
	GPS1... and GPS2...	100V 50/60Hz	GPAULRAA11	102625	10

With 2NO early make auxiliary contacts

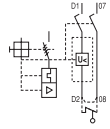

Description	For use with	Coil voltage	Cat. no.	Ref. no.	Pack.
Side mounting on the right Can not be used together with the shunt trip device	GPS1*S...	24V 50Hz	GPAU20LTAAD	101341	10
	GPS1*S...	24V 60Hz	GPAU20LTAAC	101342	10
	GPS1*S...	48V 50Hz	GPAU20LTAAG	101343	10
	GPS1*S...	48V 60Hz	GPAU20LTAAF	101344	10
	GPS1*S...	110/127V 50Hz / 120V 60Hz	GPAU20LTAAJ	101345	10
	GPS1*S...	208V 60Hz	GPAU20LTAAM	101346	10
	GPS1*S...	220/230V 50Hz / 240/260V 60Hz	GPAU20LTAAN	101347	10
	GPS1*S...	240V 50Hz / 277V 60Hz	GPAU20LTAAR	101348	10
	GPS1*S...	380/400V 50Hz	GPAU20LTAAU	101349	10
	GPS1*S...	415/440V 50Hz / 460/480V 60Hz	GPAU20LTAAW	101350	10
	GPS1*S...	500V 50Hz / 600V 60Hz	GPAU20LTAAY	101351	10
	GPS1*S...	100V 50/60Hz	GPAU20LTA11	110360	10

With 2NO early make auxiliary contacts

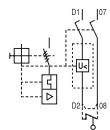

Description	For use with	Coil voltage	Cat. no.	Ref. no.	Pack.
Side mounting on the right Can not be used together with the shunt trip device	GPS1*H and GPS2...	24V 50Hz	GPAU20LCAAD	101352	10
	GPS1*H and GPS2...	24V 60Hz	GPAU20LCAAC	101353	10
	GPS1*H and GPS2...	48V 50Hz	GPAU20LCAAG	101354	10
	GPS1*H and GPS2...	48V 60Hz	GPAU20LCAAF	101355	10
	GPS1*H and GPS2...	110/127V 50Hz / 120V 60Hz	GPAU20LCAAJ	101356	10
	GPS1*H and GPS2...	208V 60Hz	GPAU20LCAAM	101357	10
	GPS1*H and GPS2...	220/230V 50Hz / 240/260V 60Hz	GPAU20LCAAN	101358	10
	GPS1*H and GPS2...	240V 50Hz / 277V 60Hz	GPAU20LCAAR	101359	10
	GPS1*H and GPS2...	380/400V 50Hz	GPAU20LCAAU	101360	10
	GPS1*H and GPS2...	415/440V 50Hz / 460/480V 60Hz	GPAU20LCAAW	101361	10
	GPS1*H and GPS2...	500V 50Hz / 600V 60Hz	GPAU20LCAAY	101362	10
	GPS1*H and GPS2...	100V 50/60Hz	GPAU20LCA11	112185	10

Terminal protector

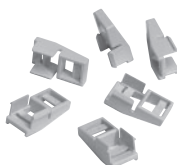

101509

107182



Description	For use with	Cat. no.	Ref. no.	Pack.
Snap-in tabs for screw mounting (set of 10)	GPS1*	GPAKS1A	101509	1
IP20 terminal covers	GPS2*	GPAPT2A	107182	50
DIN rail vibration clamps	GPS1* / GPS2*	GPVDA	101514	2
Panel vibration clamps	GPS1* / GPS2*	GPVPA	101515	2
Increases vibration resistance of GPS1* from 5G to 8G (5-150 Hz) in all directions. One clamp must be mounted on each side which increases total mounting width by 22 mm (0.87"). For vibration resistance of GPS2*, contact customers service.				



External handle operator

	Description	For use with	Type	Cat. no.	Ref. no.	Pack.
	Used for distance mounting on a panel	GPS1*H...	Standard (black)	GPA1HAB	101363	5
		GPS1*H ...	Emergency (red/yellow)	GPA1HAR	101364	5
	Lockable with 1, 2 or 3 padlocks diameter 4 to 8 mm	GPS2...	Standard (black)	GPA2HAB	101502	5
		GPS2 ...	Emergency (red/yellow)	GPA2HAR	101503	5
	Two types: standard and emergency applications ON/OFF/TRIPPING position marking Protection degree: IP54 Shaft mounting depths: 139.8 - 289.8 mm for GPA1HAB, GPA1HAR 161 - 311.1 mm for GPA2HAB, GPA2HAR Package parts and quantities: 1 handle unit 1 shaft 1 shaft guide 1 latch (screws) 4 mounting screws					

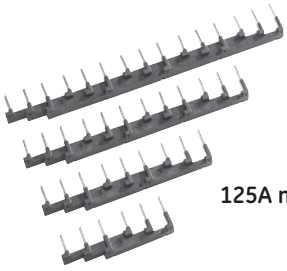
Busbar system

	Description	For use with	Connection	Cat. no.	Ref. no.	Pack.
 <p>3-phase feed-in terminals</p>	Main feeding terminal Upper connection	GPS1...	Terminal capacity: 25 mm ² Pin	GPB1FA	107186	10
		GPS2...	Terminal capacity: 50 mm ² Pin	GPB2FA	107187	10
		GPS1...	Terminal capacity: 25mm ² Fork	SFVB8	254537	1
 <p>Main busbar 63A max. 125A max.</p>	Modular spacing 45 mm	for 2 GPS1... + frontal auxiliaries	Pin	GPB1B02A	101390	5
		for 3 GPS1... + frontal auxiliaries	Pin	GPB1B03A	101391	5
		for 4 GPS1... + frontal auxiliaries	Pin	GPB1B04A	101392	5
		for 5 GPS1... + frontal auxiliaries	Pin	GPB1B05A	101393	5
	Modular spacing 54 mm	for 2 GPS1... + 9mm lateral aux.	Pin	GPB1B12A	101394	5
		for 3 GPS1... + 9mm lateral aux.	Pin	GPB1B13A	101395	5
		for 4 GPS1... + 9mm lateral aux.	Pin	GPB1B14A	101396	5
		for 5 GPS1... + 9mm lateral aux.	Pin	GPB1B15A	101397	5
	Modular spacing 63 mm	for 2 GPS1... + 18mm lateral aux. or 2 x 9mm lateral auxiliary	Fork	GPB1B22A	101398	10
		for 4 GPS1... + 18mm lateral aux. or 2 x 9mm lateral auxiliary	Fork	GPB1B24A	101399	10
Modular spacing 55 mm	for 2 GPS2... + frontal auxiliaries	Pin	GPB2B02A	101400	1	
	for 3 GPS2... + frontal auxiliaries	Pin	GPB2B03A	101401	1	
	for 4 GPS2... + frontal auxiliaries	Pin	GPB2B04A	101402	1	
Modular spacing 64 mm	for 2 GPS2... + 9mm lateral aux.	Pin	GPB2B12A	101403	1	
	for 3 GPS2... + 9mm lateral aux.	Pin	GPB2B13A	101404	1	
	for 4 GPS2... + 9mm lateral aux.	Pin	GPB2B14A	101405	1	
Modular spacing 73 mm	for 2 GPS2... + 18mm lateral aux. or 2 x 9mm lateral auxiliary	Pin	GPB2B22A	101406	1	
	for 4 GPS2... + 18mm lateral aux. or 2 x 9mm lateral auxiliary	Pin	GPB2B24A	101407	1	
 <p>Busbar cover</p>	Touch guard for non used space	GPS1...	Pin	GPB1GA	101408	10
		GPS1...	Fork	GPB1GAF	101511	1
		GPS2...	Pin	GPB2GA	101409	10
 <p>Terminal cover type E</p>	For compliance UL508E	GPS1...H	-	GPAPT1E	107315	1
	When using a Surion GPS1*BH as a manual self-protected combination motor starter (Type E). Cover enables compliance with NEC Section 430-52, 1" over air creepage and over surface clearance, phase to phase on the line side.					

Order codes

Intro

A

B

C

D

E

F

G

H

I

J/X



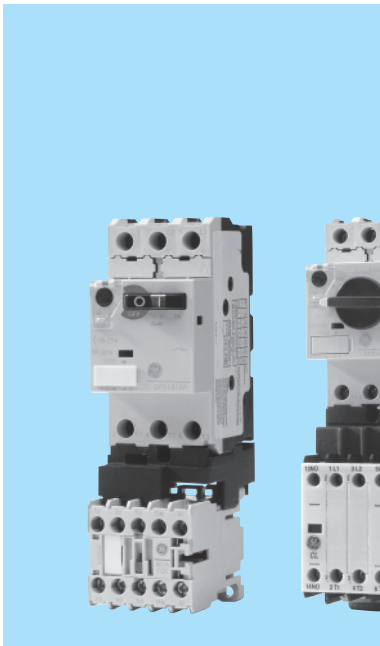

Fuseless starters and busbar adapter plates

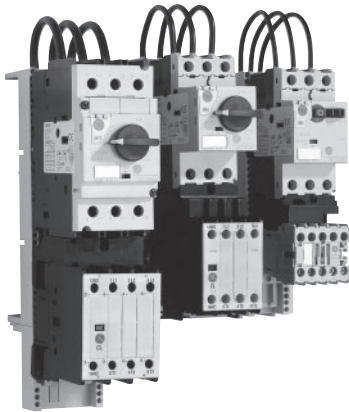

Product range

- Link modules for mechanical and electrical connection of the manual motor starter and the M / CL contactor range
- Base plates for Din rail and busbar adapters
- Wiring kits for reversing applications
- Link connection for two base plates for three phase busbar system with 40 and 60mm center line spacing and 5 to 10mm thickness
- Accessories

Technical performances

- Compact and high performance solution
- Easy accessibility to the contactor coil terminal A1-A2
- Save spacing only using 45 and 55mm width base plates for busbar adapters
- Quick “clip on” and secure connections
- Minimum 50kA short-circuit breaking capacity applies throughout

For fuseless starter application turn the contactor 180° to have direct accessibility to the A1-A2 coil terminals when contactor is assembled to the manual motor starter. Then fit the contactor plastic cover into the contactor front to have the terminal numbering in the correct position.

Note: when turning the contactor 180° the built-in auxiliary contact (in case) will be located on the first left side terminal.

Thermal and magnetic protection



- GPS1B ● pg. C.2
- GPS2B ● pg. C.4
- GPS1M ● pg. C.6
- GPS2M ● pg. C.8

Contactors

- Serie M ● pg. A.44
- Serie CL ● pg. A.52

- Coordination tables ● pg. D.11
- Dimensions ● pg. D.40

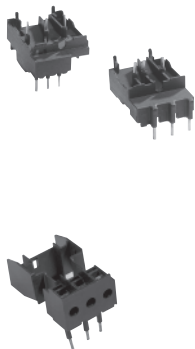
Fuseless starters

	Description	For use with contactor	ac/dc	Frame size	Cat. no.	Ref. no.	Pack.					
Link modules 	For mechanical and electrical connection between contactors and manual motor starters	MC0.., MC1..	ac/dc	GPS1	GPF1LMCBA	101410	5					
		CL00A..., CL01A..., CL02A..	ac	GPS1	GPF1L02AA	101411	5					
		CL00D..., CL01D..., CL02D..	dc	GPS1	GPF1L02DA	101412	5					
		CL25A..	ac	GPS1	GPF1L25AA	101413	5					
		CL25D..	dc	GPS1	GPF1L25DA	101414	5					
		CL03A..., CL04A..	ac	GPS1	GPF1L04AA	107165	5					
		CL03D..., CL04D..	dc	GPS1	GPF1L04DA	107166	5					
		CL03A..., CL04A..	ac	GPS2	GPF2L04AA	107190	5					
		CL45A..	ac	GPS2	GPF2L45AA	101415	5					
		CL03D..., CL04D..	dc	GPS2	GPF2L04DA	107191	5					
		CL45D..	dc	GPS2	GPF2L45DA	101416	5					
		CL06A..., CL07A..	ac	GPS2	GPF2L07AA	101417	5					
		Record Plus with CL09/10A										
		For mechanical and electrical connection between contactor and thermal overload relays RT1	CL00.. - CL25	ac/dc	GPS1	GPF1L25CT1	101512	5				
	CL03.. - CL45	ac/dc	GPS2	GPF1L45CT1	101513	5						
Base plates 	Plastic plates for mounting the fuseless starter in panels or in 35 mm DIN rail	CL00.., CL01.., CL02.., CL25..	ac/dc	GPS1	GPF1B1A	101418	5					
		CL03..., CL04... and CL45..	ac/dc	GPS2	GPF2B2A	101419	5					
		CL06.., CL07..	ac/dc	GPS2	GPF2B3A	101420	5					
		CL03..., CL04..	ac/dc	GP	GPF1B4A	107163	5					
Base plates Link connector	For use with MCCB Record Plus	-	-	-	GPF3B5A	107253	1					
	For two base plates for reversing applications	-	-	-	GPF1CBA	101427	10					
Plastic cover 	Description	For use with contactor			Cat. no.	Ref. no.	Pack.					
								Fit the plastic cover into the front of the correspondent contactor to allow a clear identification of the terminal numbering	CL00.., CL01.. and CL02 without built-in auxiliary contact	GPF00C02	107098	5
									CL00.., CL01.. and CL02 with built-in 1NO auxiliary contact	GPF10C02	107099	5
									CL00.., CL01.. and CL02 with built-in 1NC auxiliary contact	GPF01C02	107100	5
									CL25..	GPF00C25	107101	2
									CL03..., CL04.. without built-in auxiliary contact	GPF00C04	107102	5
									CL03..., CL04.. with built-in 1NO auxiliary contact	GPF10C04	107103	5
									CL03..., CL04.. with built-in 1NC auxiliary contact	GPF01C04	107105	5
									CL45..	GPF00C45	107106	5
									CL06..., CL07..	GPF00C08	107107	5

Order codes

Intro

A

B

C

D

E

F

G

H

I

J/X





Enclosures for manual motor starters

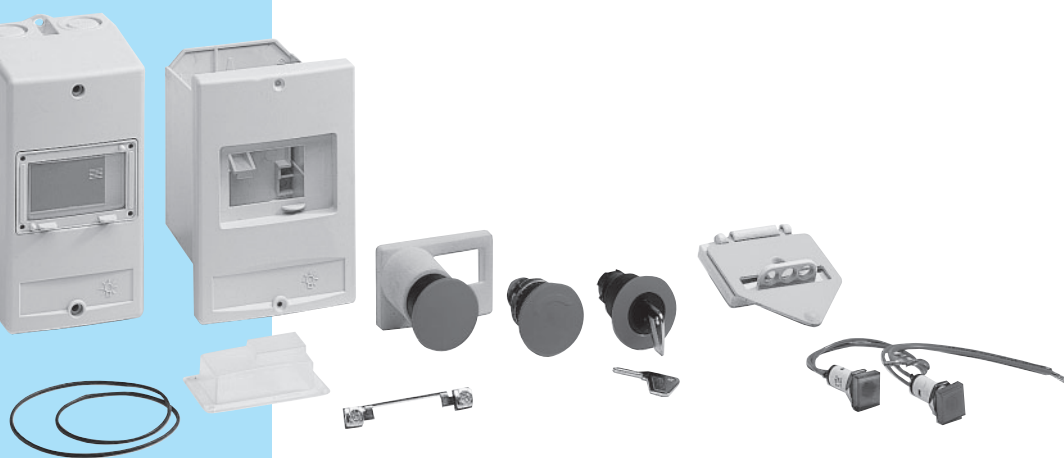

Product range

- Surface and flush mounting plastic enclosures (IP41 and IP55)
- Neutral and ground connection
- Three different types of push-buttons
 - Mushroom with impulse function
 - Mushroom self latching, unlatching by turning
 - Mushroom self latching, unlatching with a key
- Indicator lamps
- Padlocking device for three padlocks
- Conversion kit IP41 to IP55

Technical performances

- Used with GPS1*S manual motor starters
- Protection degree IP41 or IP55
- Possibility to mount frontal/lateral auxiliary contact blocks with an undervoltage release (without or with 2NO early make auxiliary contacts) inside the enclosures

Manual motor starter

- GPS1B ● pg. C.2
- GPS2B ● pg. C.4
- GPS1M ● pg. C.6
- GPS2M ● pg. C.8

Intro

A

B

C

D

E

F

G

H



I

J/X

Enclosures for only GPS 1*S

	Description	Cat. no.	Ref. no.	Pack.
 Plastic enclosures	Surface mounting IP41	GPE41A	101365	1
	Surface mounting IP55	GPE55A	101366	1
	Flush mounting IP41	GPEF41A	101367	1
	Flush mounting IP55	GPEF55A	101368	1

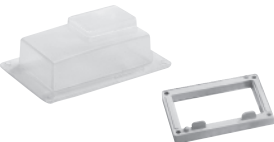
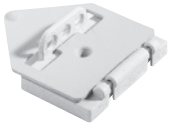
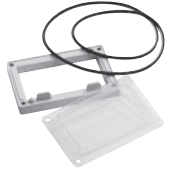
Mounting accessories for all enclosures

	Description	Cat. no.	Ref. no.	Pack.
 Neutral connection	To be used inside the enclosure	GPENA	101369	1
 Adaptor set	For enclosures used with GPS1*S and undervoltage release with 2 NO auxiliary contacts	GPEUTA	107097	1
 Padlocking device	For three padlocks with max. 8 mm shackle diameter Not to be used with emergency stop handle	GPEPA	101370	1
 Conversion kit IP41 to IP55		GPECA	101371	1
 Mushroom push-button	Mushroom spring return	GPEPMA	101372	1
	Mushroom self latching, turn to release	GPEPLA	101373	1
	Mushroom self latching, release with a key	GPEPKA	101374	1
 Indicator lamps	Green 110/120V	GPELGAJ	101375	1
	Green 220/240V	GPELGAN	101376	1
	Green 380/440V	GPELGAU	101377	1
	Green 480/500V	GPELGAX	101378	1
	Green 600V	GPELGAY	101379	1
	Red 110/120V	GPELRAJ	101380	1
	Red 220/240V	GPELRAN	101381	1
	Red 380/440V	GPELRAU	101382	1
	Red 480/500V	GPELRAX	101383	1
	Red 600V	GPELRAY	101384	1
	Transparent 110/120V	GPELCAJ	101385	1
	Transparent 220/240V	GPELCAN	101386	1
	Transparent 380/440V	GPELCAU	101387	1
	Transparent 480/500V	GPELCAX	101388	1
Transparent 600V	GPELCAY	101389	1	

Technical data

General data

Frame size	GPS1	GPS2
Rated insulation voltage Ui	690V	1000V
Rated operating voltage Ue	690V ac	690V ac
Rated impulse withstand strength Uimp	6kV	8kV
Rated frequency	50/60Hz	50/60Hz
Total power loss P (W)	0.16 to 25A 7W 32A 8.5W	up to 32A 11W 40A to 50A 15W 63A 17W
Utilisation category:		
IEC 947-2 (Circuit breaker)	Cat. A	Cat. A
IEC 947-4-1 (Motor starter)	AC3	AC3
Mechanical operational performance	100,000 (70,000 for 32A)	50,000
Electrical operational performance	100,000 (70,000 for 32A)	25,000
Max. operations per hour (motor start-up)	25	25
Ambient conditions:		
Storage temperature	-40°C to +80°C	-40°C to +80°C
Operation temperature	-25°C to +60°C	-25°C to +60°C
Temperature compensation	-20°C to +60°C	-20°C to +60°C
Ambient temperature compensation	yes	yes
Operational altitude	up to 2000m	up to 2000m
Shock resistance (IEC 68)	30g (width 20ms)	30g (width 20ms)
Vibration resistance	8g (5 to 150Hz)	8g (5 to 150Hz)
Shock-hazard prot. (acc. DIN VDE 0106)	fingerproof	fingerproof
Protection degree (acc. to IEC529)	IP20	IP10 (IP20 with acc GPAPT2A)
Rated current Ie	up to 32A	up to 63A
Overload protection	IEC 947-4-1	IEC 947-4-1
Phase failure protection	yes	yes
Tripping class	10	10
Magnetic release (factory set)	13 x Iemax	13 x Iemax
Test trip button	yes	yes
Standards & Approvals		
IEC 947-1 / -2 / -4-1	yes	yes
DIN VDE 0660T 100 / 101 / 102	yes	yes
UL508	yes	yes
UL508 type E	Only GPS1*H	yes
CE	yes	yes
cULus	yes	yes
D / S / N / Fi	In process	-
Shipping approvals	yes	yes

Mounting data

Terminal capacity:		
Solid or stranded without end sleeve	1 x 1...10 mm ² 2 x 1...6 mm ²	1 or 2 x 1...25 mm ²
Stranded with end sleeve	1 or 2 x 1...6 mm ²	1 x 1...25 mm ² / 2 x 1...16 mm ²
AWG	1 x 18...8 / 2 x 18...10	1 x 18...2 / 2 x 18...4
Operating mechanism lockable in OFF position diameter (mm)	3.5 to 4.5	3.5 to 4.5
Terminal type	screw	box
Tightening torque	2 Nm / 18Lb.in	5 Nm / 45 Lb.in
Screwdriver	Pz2 / slotted combination	Pz2 / slotted combination
Mounting:		
DIN-rail	yes	yes
Screws	no	yes
Operating position:		
turning to the front	30°	30°
turning to the back	90°	90°
turning to both sides	180°	180°
Handle operation	Rocker level / Rotary	Rotary
Dimensions		
width (mm)	45	55
height (mm)	90	120
depth (mm)	(GPS1*S) 75 / 92.5 (GPS1*H)	107.5



Ultimate short-circuit breaking capacity (I_{cu}) in kA

		For ranges GPS1BSA* / GPS1MSA*																	
Rated current (A)		A	B	C	D	E	F	G	H	J	K	L	M	N	P	R	S	T	U
		1.6	0.25	0.4	0.63	1	1.6	2.5	4	6.3	10	13	16	20	25	32	40	50	63
220/230V		100	100	100	100	100	100	100	100	100	100	100	100	50	50	50	-	-	-
400/415V		100	100	100	100	100	100	100	100	100	100	50	25	25	25	25	-	-	-
440V		100	100	100	100	100	100	100	100	50	15	10	10	10	10	10	-	-	-
500/525V		100	100	100	100	100	100	100	50	10	6	6	6	6	6	6	-	-	-
600V		100	100	100	100	100	100	3	3	3	3	3	3	3	3	3	-	-	-
690V		100	100	100	100	100	100	3	3	3	3	3	3	3	3	3	-	-	-
		For ranges GPS1BHA* / GPS1MHA*																	
220/230V		100	100	100	100	100	100	100	100	100	100	100	100	100	100	100	-	-	-
400/415V		100	100	100	100	100	100	100	100	100	100	50	50	50	50	50	-	-	-
440V		100	100	100	100	100	100	100	100	50	50	35	35	35	35	-	-	-	
500/525V		100	100	100	100	100	100	100	100	50	42	10	10	10	10	-	-	-	
600V		100	100	100	100	100	100	8	8	6	6	4	4	4	4	-	-	-	
690V		100	100	100	100	100	100	8	8	6	6	4	4	4	4	-	-	-	
		For ranges GPS2BSA* / GPS2MSA*																	
220/230V		-	-	-	-	-	-	-	-	-	100	100	100	50	50	50	50	50	50
400/415V		-	-	-	-	-	-	-	-	-	100	50	25	25	25	25	25	25	25
440V		-	-	-	-	-	-	-	-	-	15	10	10	10	10	10	10	10	10
500/525V		-	-	-	-	-	-	-	-	-	10	6	6	6	6	6	5	5	5
600V		-	-	-	-	-	-	-	-	-	4	4	4	4	4	4	4	4	4
690V		-	-	-	-	-	-	-	-	-	4	4	4	4	4	4	4	4	4
		For ranges GPS2BHA* / GPS2MHA*																	
220/230V		-	-	-	-	-	-	-	-	-	100	100	100	100	100	100	100	100	100
400/415V		-	-	-	-	-	-	-	-	-	100	100	50	50	50	50	50	50	50
440V		-	-	-	-	-	-	-	-	-	50	50	50	50	35	35	35	35	35
500/525V		-	-	-	-	-	-	-	-	-	50	42	12	12	12	10	10	10	10
600V		-	-	-	-	-	-	-	-	-	6	6	5	5	5	5	5	5	5
690V		-	-	-	-	-	-	-	-	-	6	6	5	5	5	5	5	5	5

Short-circuit proof with an I_{cu} = 100kA or 50kA

Rated service short-circuit breaking capacity (I_{cs}) in kA

		For ranges GPS1BSA* / GPS1MSA*																	
Rated current (A)		A	B	C	D	E	F	G	H	J	K	L	M	N	P	R	S	T	U
		1.6	0.25	0.4	0.63	1	1.6	2.5	4	6.3	10	13	16	20	25	32	40	50	63
220/230V		100	100	100	100	100	100	100	100	100	100	100	100	38	38	38	-	-	-
400/415V		100	100	100	100	100	100	100	100	100	100	38	19	19	19	19	-	-	-
440V		100	100	100	100	100	100	100	100	38	11	8	8	8	8	8	-	-	-
500/525V		100	100	100	100	100	100	100	100	38	8	5	5	5	5	5	-	-	-
600V		100	100	100	100	100	100	3	3	3	3	3	3	3	3	3	-	-	-
690V		100	100	100	100	100	100	3	3	3	3	3	3	3	3	3	-	-	-
		For ranges GPS1BHA* / GPS1MHA*																	
220/230V		100	100	100	100	100	100	100	100	100	100	100	100	100	100	100	-	-	-
400/415V		100	100	100	100	100	100	100	100	100	100	38	38	25	25	25	-	-	-
440V		100	100	100	100	100	100	100	100	38	38	25	25	25	25	-	-	-	
500/525V		100	100	100	100	100	100	100	100	38	32	8	8	8	8	-	-	-	
600V		100	100	100	100	100	100	6	6	5	5	5	3	3	3	-	-	-	
690V		100	100	100	100	100	100	6	6	5	5	5	3	3	3	-	-	-	
		For ranges GPS2BSA* / GPS2MSA*																	
220/230V		-	-	-	-	-	-	-	-	-	100	100	100	38	38	38	38	38	38
400/415V		-	-	-	-	-	-	-	-	-	100	32	19	19	19	19	19	19	19
440V		-	-	-	-	-	-	-	-	-	12	8	8	8	8	8	8	8	8
500/525V		-	-	-	-	-	-	-	-	-	8	5	5	5	5	5	4	4	4
600V		-	-	-	-	-	-	-	-	-	3	3	3	3	3	3	3	3	3
690V		-	-	-	-	-	-	-	-	-	3	3	3	3	3	3	3	3	3
		For ranges GPS2BHA* / GPS2MHA*																	
220/230V		-	-	-	-	-	-	-	-	-	100	100	100	100	100	100	100	100	100
400/415V		-	-	-	-	-	-	-	-	-	100	100	38	38	38	38	38	38	38
440V		-	-	-	-	-	-	-	-	-	38	38	38	38	25	25	25	25	25
500/525V		-	-	-	-	-	-	-	-	-	38	32	9	9	9	8	8	8	8
600V		-	-	-	-	-	-	-	-	-	5	5	4	4	4	4	4	4	4
690V		-	-	-	-	-	-	-	-	-	5	5	4	4	4	4	4	4	4

Back-up fuses are necessary in case of possibility of a short-circuit current higher than 100kA or 50kA at the installation point of the device (on request)

I_{cs} = 100%I_{cu} when I_{cu} = 100kA
I_{cs} = 75%I_{cu} when I_{cu} < 100kA



Back-up gl/gG fuses only if $I_{cs} > I_{cu}$ (kA)

		For ranges GPS1BSA* / GPS1MSA*																	
gl/gG fuses (A)		A	B	C	D	E	F	G	H	J	K	L	M	N	P	R	S	T	U
		1.6	0.25	0.4	0.63	1	1.6	2.5	4	6.3	10	13	16	20	25	32	40	50	63
230V	#	#	#	#	#	#	#	#	#	#	#	#	#	100	100	100	-	-	-
400V	#	#	#	#	#	#	#	#	#	#	#	80	100	100	100	100	-	-	-
440V	#	#	#	#	#	#	#	#	#	50	63	63	80	80	80	80	-	-	-
500V	#	#	#	#	#	#	#	#	#	50	50	63	63	63	80	80	-	-	-
600V	#	#	#	#	#	#	#	20	32	40	50	63	63	63	80	80	-	-	-
690V	#	#	#	#	#	#	#	20	32	40	50	50	63	63	63	63	-	-	-
		For ranges GPS1BHA* / GPS1MHA*																	
230V	#	#	#	#	#	#	#	#	#	#	#	#	#	#	#	#	-	-	-
400V	#	#	#	#	#	#	#	#	#	#	#	#	100	125	125	125	-	-	-
440V	#	#	#	#	#	#	#	#	#	#	63	63	80	80	100	100	-	-	-
500V	#	#	#	#	#	#	#	#	#	#	50	63	80	80	80	80	-	-	-
600V	#	#	#	#	#	#	#	25	40	50	50	63	63	63	80	80	-	-	-
690V	#	#	#	#	#	#	#	25	40	50	50	63	63	63	63	63	-	-	-
		For ranges GPS2BSA* / GPS2MSA*																	
230V	-	-	-	-	-	-	-	-	-	-	#	#	#	125	125	125	125	125	160
400V	-	-	-	-	-	-	-	-	-	-	#	80	100	125	125	125	125	125	160
440V	-	-	-	-	-	-	-	-	-	-	63	63	80	80	100	100	125	125	125
500V	-	-	-	-	-	-	-	-	-	-	63	63	80	80	80	80	100	100	125
600V	-	-	-	-	-	-	-	-	-	-	63	63	63	63	80	80	100	100	100
690V	-	-	-	-	-	-	-	-	-	-	63	63	63	63	63	63	80	80	100
		For ranges GPS2BHA* / GPS2MHA*																	
230V	-	-	-	-	-	-	-	-	-	-	#	#	#	#	#	#	#	#	#
400V	-	-	-	-	-	-	-	-	-	-	#	#	100	125	125	125	125	125	160
440V	-	-	-	-	-	-	-	-	-	-	63	63	80	80	100	100	125	125	125
500V	-	-	-	-	-	-	-	-	-	-	63	63	80	80	80	80	100	100	125
600V	-	-	-	-	-	-	-	-	-	-	80	63	63	63	80	80	100	100	100
690V	-	-	-	-	-	-	-	-	-	-	80	63	63	63	63	63	63	80	100

Back-up gl/gG fuses only if $I_{cs} > I_{cu}$ (kA)

Manual motor starter: GPS1...

Manual motor starter: GPS2...

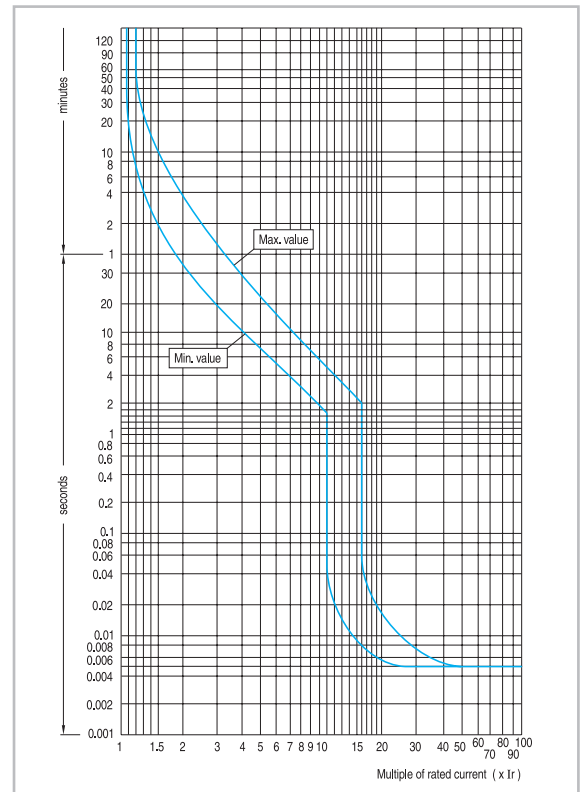
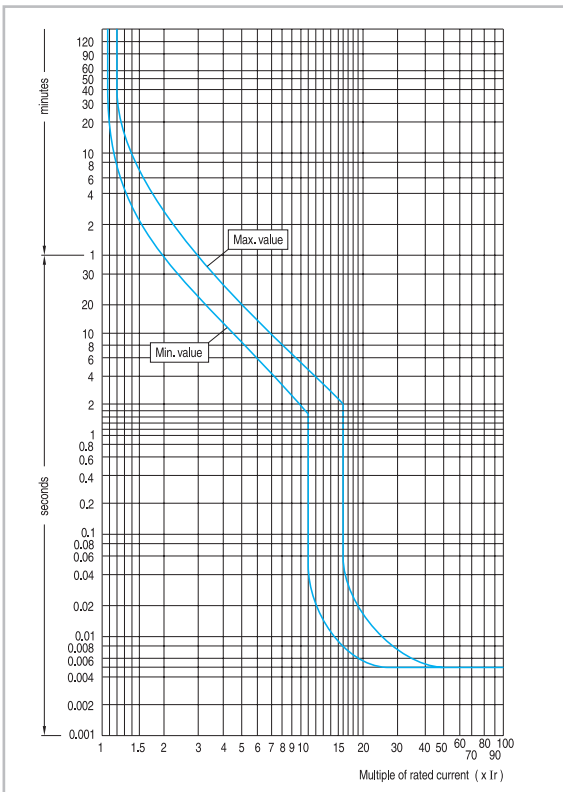

Specific let-through energy at $U_e = 400/415\text{ V}$

Manual motor starter: GPS1...

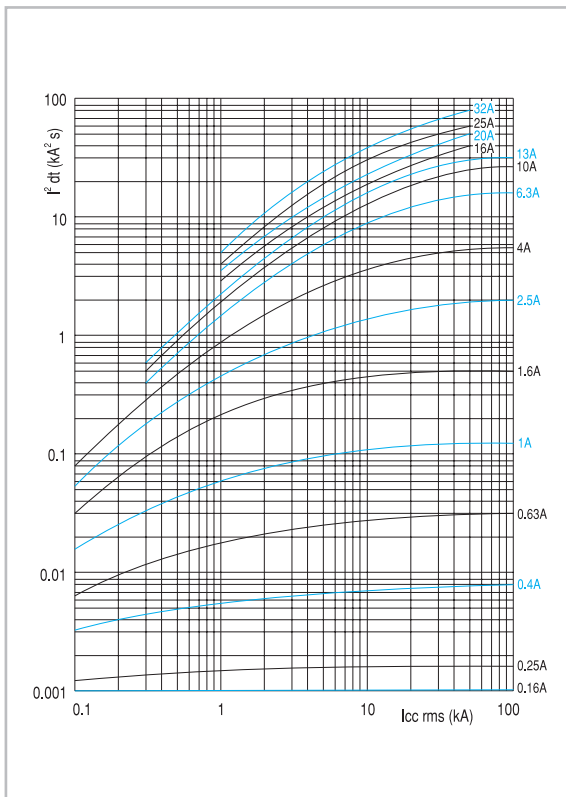

Manual motor starter: GPS2...

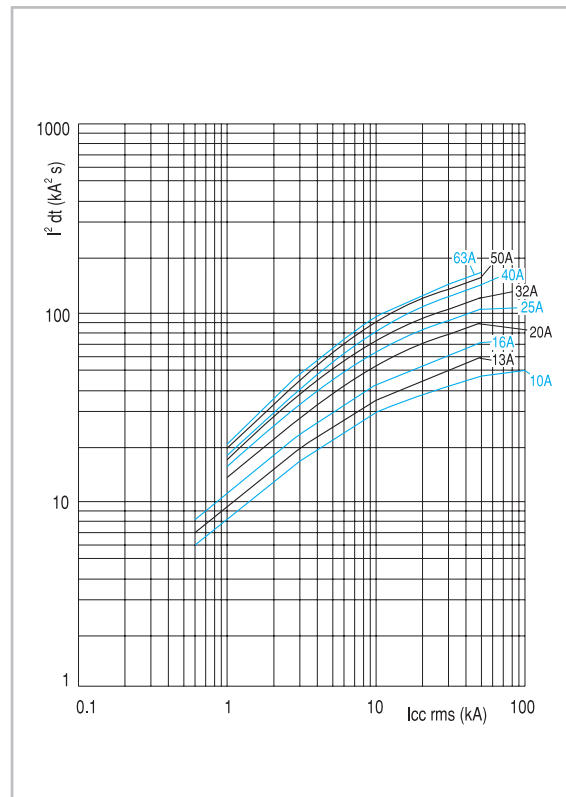

Peak current limitation at $U_e = 400/415\text{ V}$

Manual motor starter: GPS1...

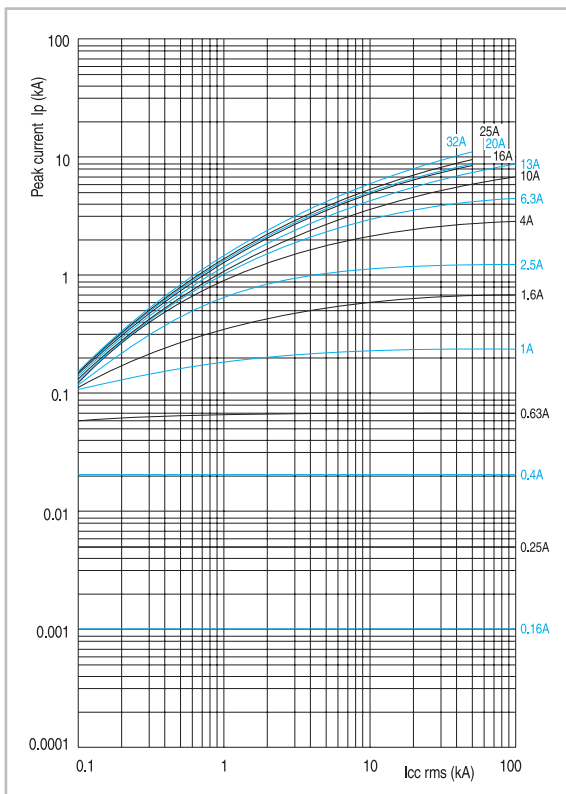

Manual motor starter: GPS2...

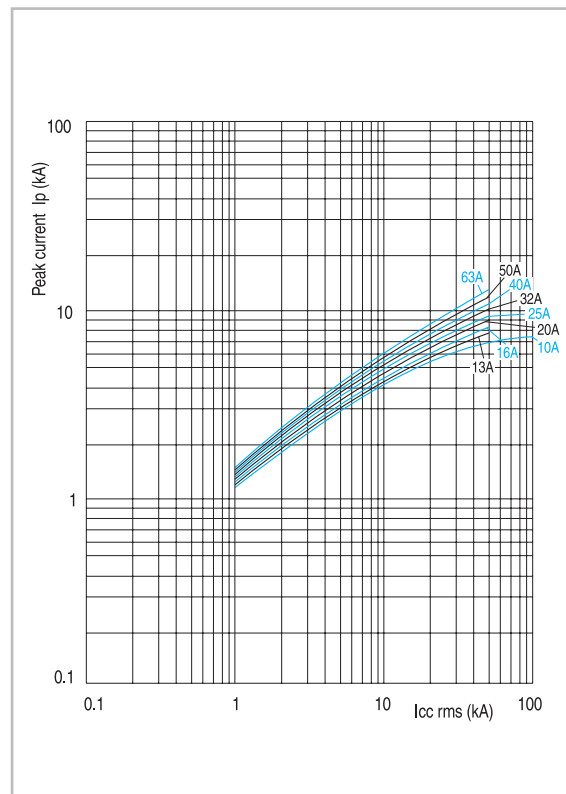

Mounting possibilities of the auxiliaries

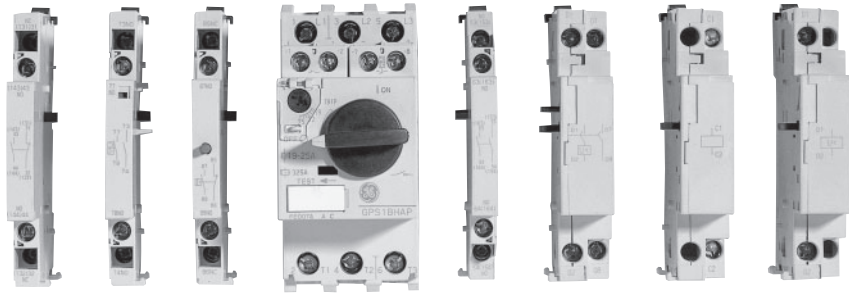

Wiring diagram	Type	Description
Frontal auxiliaries		
	Auxiliary contact block	1NO or 1NC
	Alarm contact block	1NO or 1NC
Lateral auxiliaries		
	Auxiliary contact block	2NO 1NO + 1NC 2NC
	Auxiliary/alarm contact block	1NO (alarm) + 1NO (auxiliary) 1NO (alarm) + 1NC (auxiliary) 1NC (alarm) + 1NO (auxiliary) 1NC (alarm) + 1NC (auxiliary)
	Short-circuit alarm contact block	1NO + 1NC
	Shunt trip	
	Undervoltage trip	
	Undervoltage trip with 2NO early make auxiliary contacts	

Shunt trip, undervoltage trip and undervoltage with 2NO contacts can be mounted together with any frontal block or left lateral block with above mentioned restrictions



Auxiliaries

Catalogue reference	GPAC*F..	GPAC*L..	GPAL..	GPAD..	GPAE..
	Aux. frontal block	Aux. lateral block	Alarm frontal block	Alarm/aux. lateral block	Short-circuit alarm block
Cont. cap. contacts class (UL508)	B300 / Q300	A600 / P300	B300 / Q300	A600 / P300	A600 / P300
Back-up fuses gG, gI	6A	10A	6A	10A	10A
Utilization category AC-15					
Rated operating voltage Ue (Vac)	48 125 230	48 125 230 400 500 690	48 125 230	48 125 230 400 500 690	48 125 230 400 500 690
Rated operational current (A)	5 3 1.5	6 4 4 2.2 1.5 0.6	5 3 1.5	6 4 4 2.2 1.5 0.6	6 4 4 2.2 1.5 0.6
Utilization category DC-13					
Rated operating voltage Ue (Vdc)	48 110 220	48 110 220	48 110 220	48 110 220	48 110 220
Rated operational current (A)	1.38 0.55 0.27	5 1.3 0.5	1.38 0.55 0.27	5 1.3 0.5	5 1.3 0.5
Mounting data					
Mounting side	Front	Left or right	Frontal right	Left	Left
Terminals capacity:					
Solid or stranded without end sleeve	2x0.5...2.5 mm ²	2x0.5...2.5 mm ²	2x0.5...2.5 mm ²	2x0.5...2.5 mm ²	2x0.5...2.5 mm ²
AWG	2x18...14	2x18...14	2x18...14	2x18...14	2x18...14
Terminal type	screw	screw	screw	screw	screw
Tightening torque	0.8Nm	0.8Nm	0.8Nm	0.8Nm	0.8Nm
Screwdriver	Pz2/Slotted	Pz2/Slotted	Pz2/Slotted	Pz2/Slotted	Pz2/Slotted
Dimensions width (mm)	Maintain same width	Increase width 9 mm	Maintain same width	Increase width 9 mm	Increase width 9 mm

Catalogue reference	GPAU	GPAS
	Undervoltage trip	Shunt trip
Power consumption:		
Pick-up (VA/W)	21/12	21/12
Hold (VA/W)	8/12	-
Operating voltage		
Tripping (V)	0.35Ve-0.7Ve	0.7Ve-1.1Ve
Pick-up (V)	0.85Ve-1.1Ve	-
Max. operation supply (ms)	-	5(DC)
Rated operating voltage Ue	24V 50Hz 24V 60Hz 48V 50Hz 48V 60Hz 110/127V 50Hz / 120V 60Hz 208V 60Hz 220/230V 50Hz / 240/260V 60Hz 240V 50Hz / 277V 60Hz 380/400V 50Hz 415/440V 50Hz / 460/480V 60Hz 500V 50Hz / 600V 60Hz	24V 50/60Hz 48V 60Hz 48V 50Hz / 60V 60Hz 110/127V 50Hz / 120V 60Hz 208V 60Hz 220/230V 50Hz / 240/260V 60Hz 240V 50Hz / 277V 60Hz 380/400V 50Hz 415/440V 50Hz / 460/480V 60Hz 500V 50Hz / 600V 60Hz 24 to 60Vdc 110 to 240Vdc
Contacts class (UL508)	-	-
Back-up fuses (gG,gI)	10A	10A
Mounting data		
Mounting side	Right	Right
Terminals capacity:		
Solid or stranded without end sleeve	2x0.5...2.5 mm ²	2x0.5...2.5 mm ²
AWG	2x18...14	2x18...14
Terminal type	Screw	Screw
Tightening torque	0.8Nm	0.8Nm
Screwdriver	Pz2/Slotted	Pz2/Slotted
Dimensions width (mm)	Increase width 18 mm	Increase width 18 mm

Detailed dimensions see page C.25



Dimensional drawings

Manual Motor Starter - GPS1 rocker

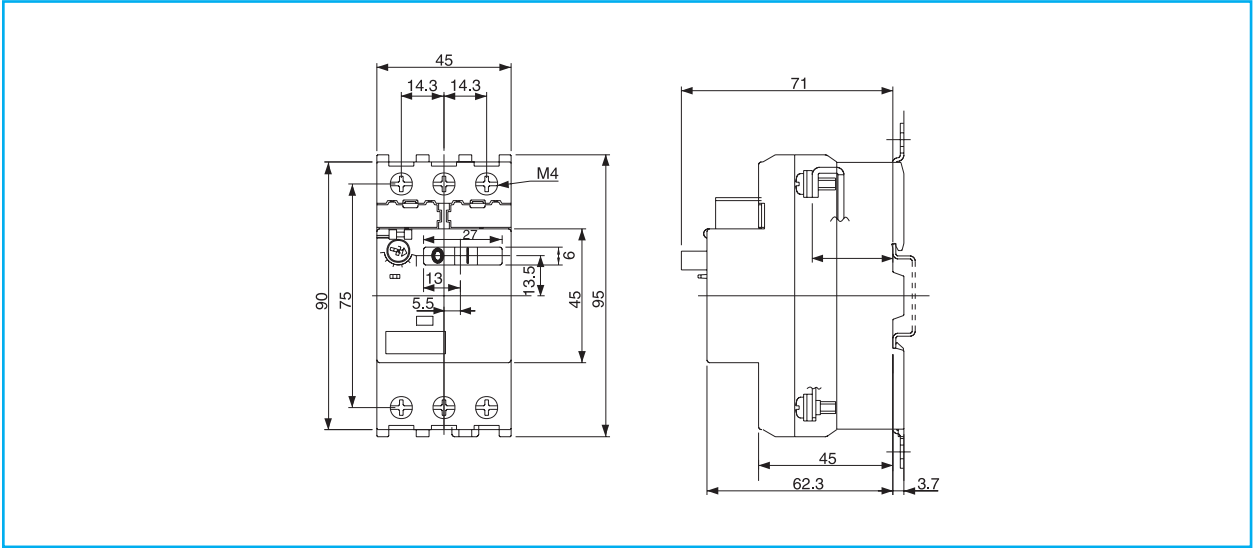

Manual Motor Starter - GPS1 rotary

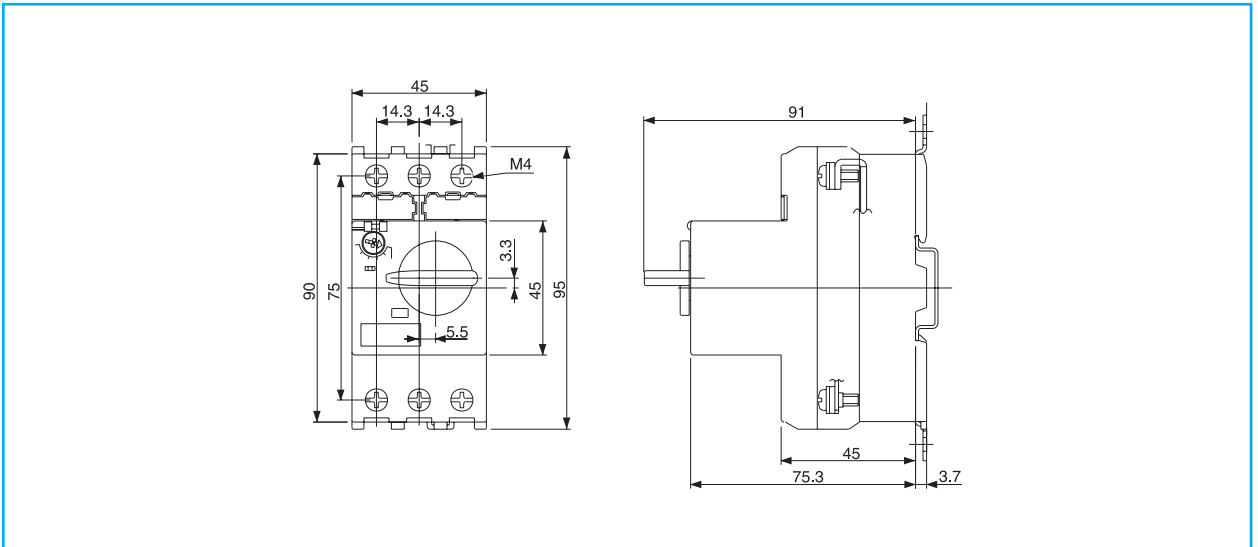

Manual Motor Starter - GPS2

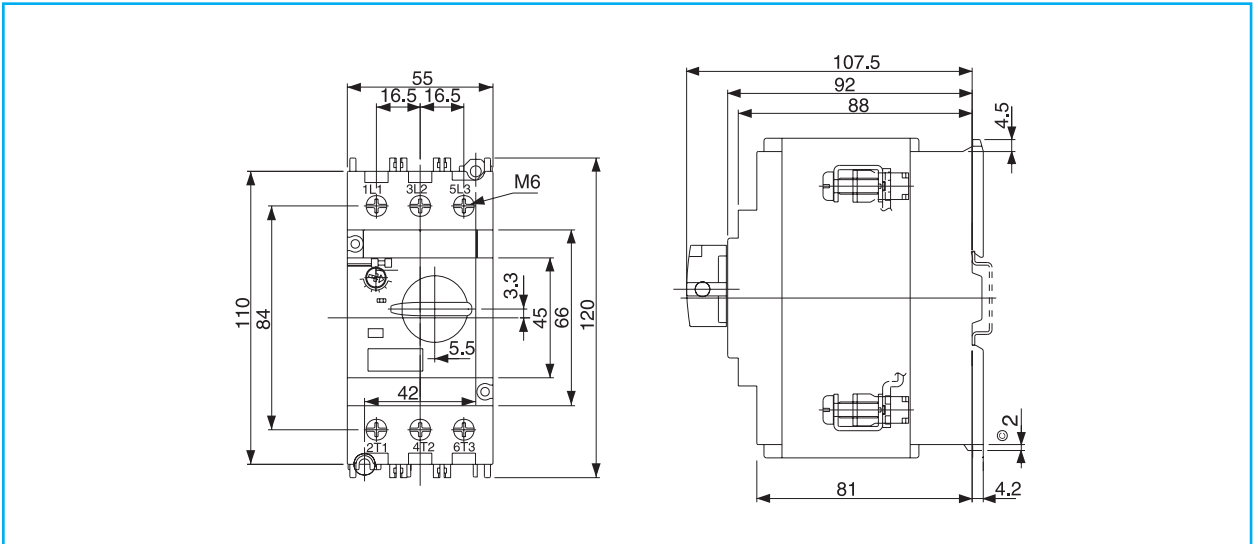

Auxiliary contact blocks

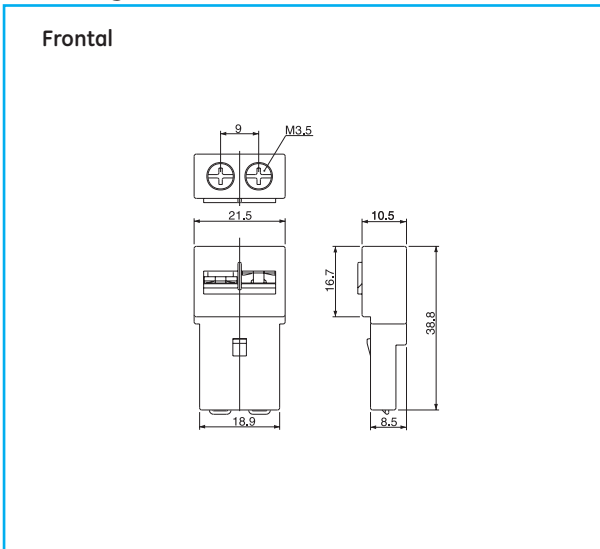

Auxiliary contact blocks

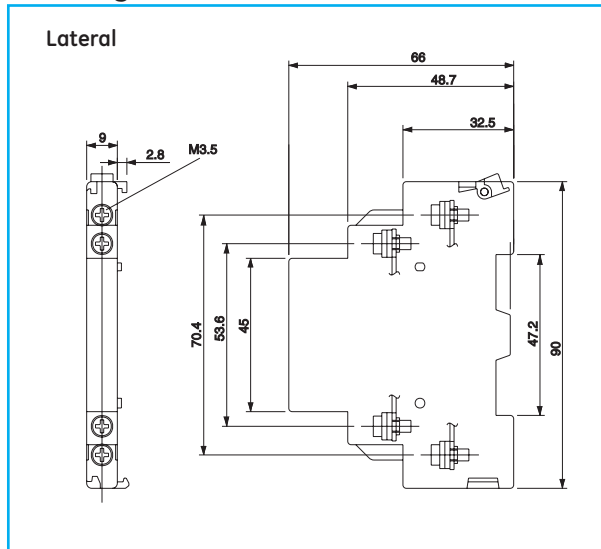

Alarm contact blocks

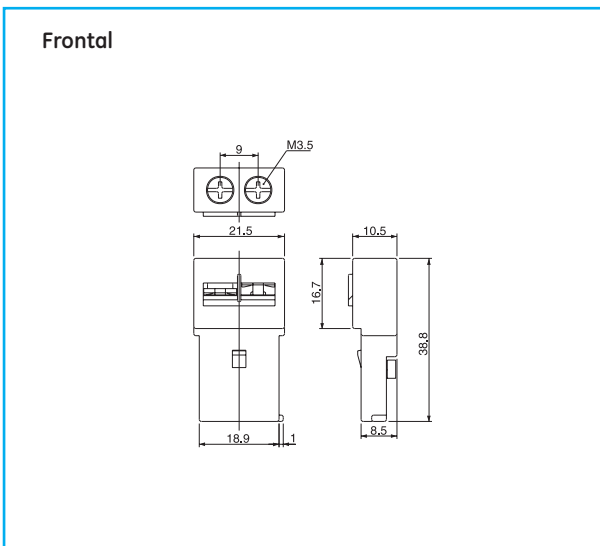

Alarm contact blocks

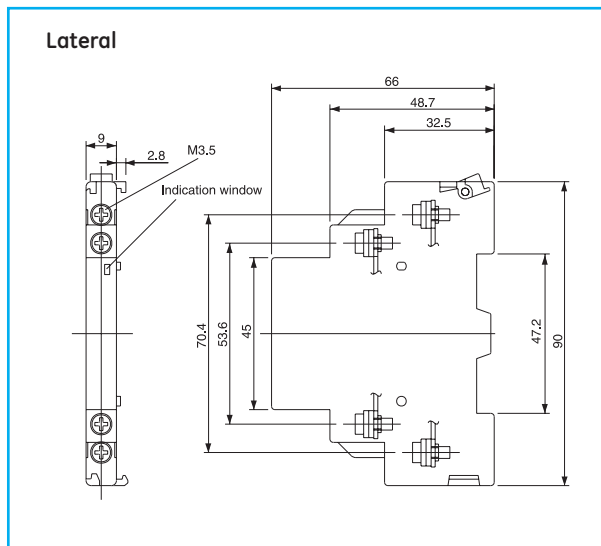

Shunt and undervoltage trip devices

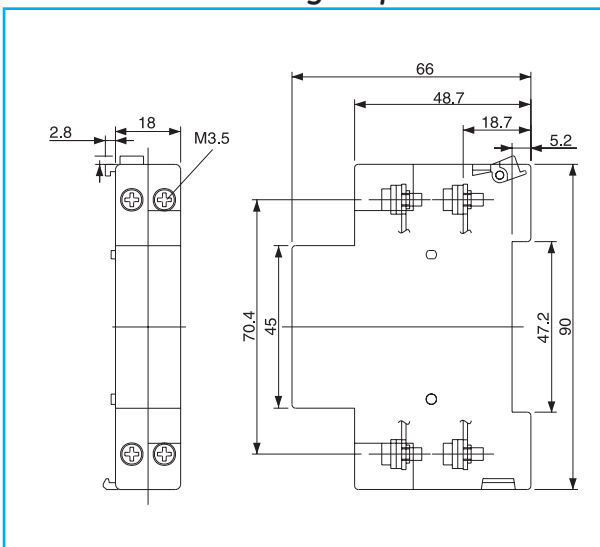

Short-circuit contact block

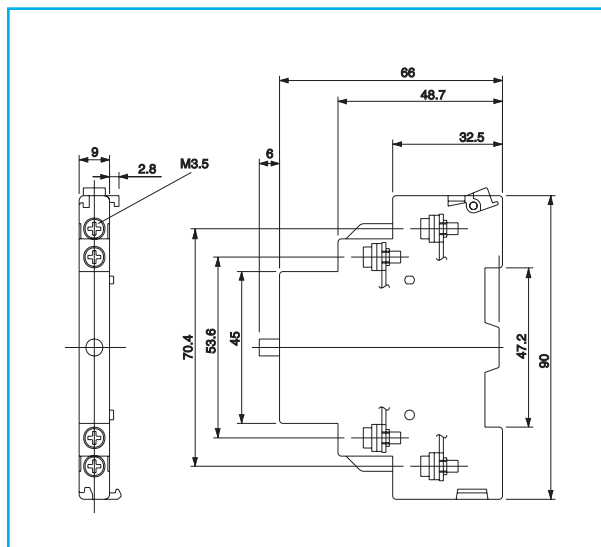

Intro

A

B

C

D

E

F

G

H

I

J/X



Dimensional drawings

GPS1 rocker + Undervoltage trip device with 2NO contacts

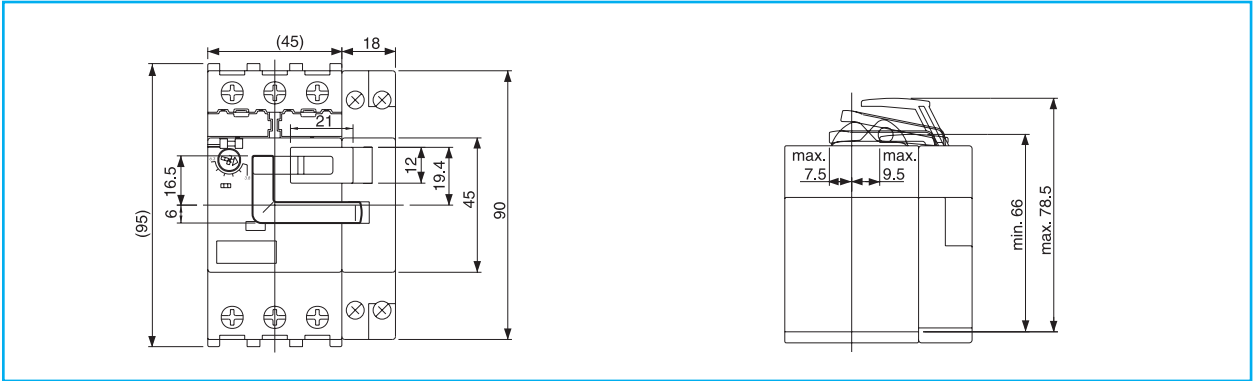

GPS1 rocker + Auxiliaries

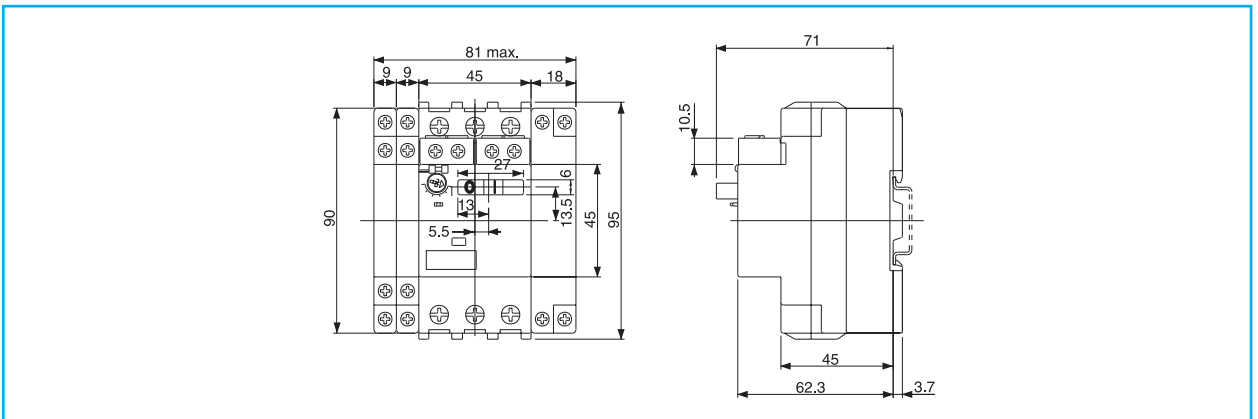

GPS1 rotary + Auxiliaries

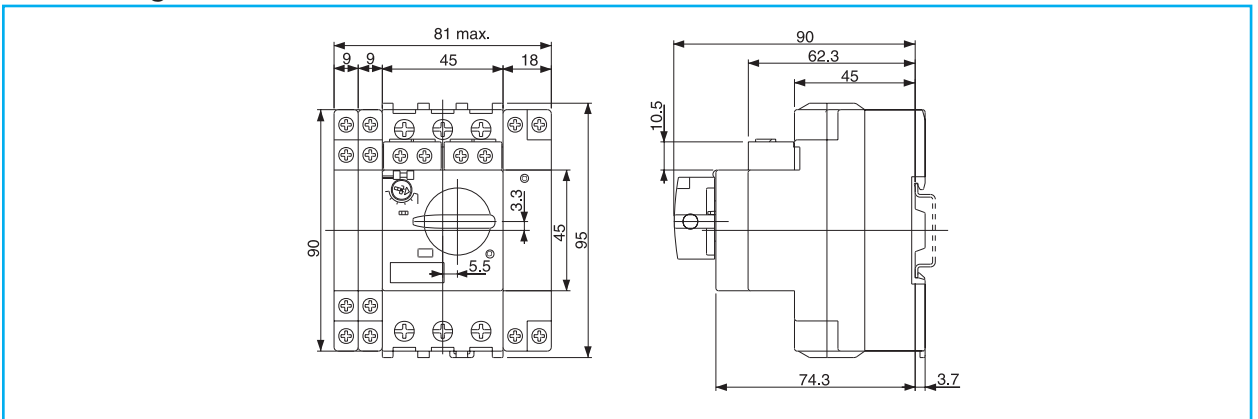

GPS2 + Auxiliaries

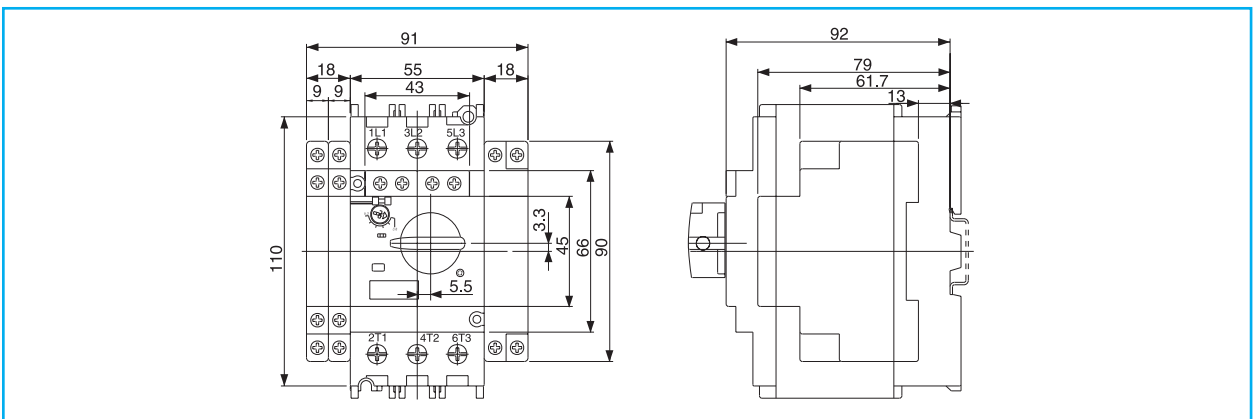

External handle operator

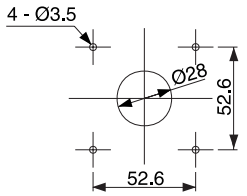
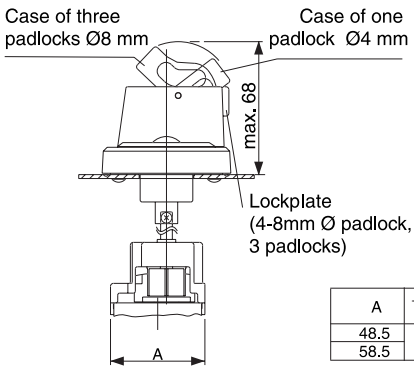
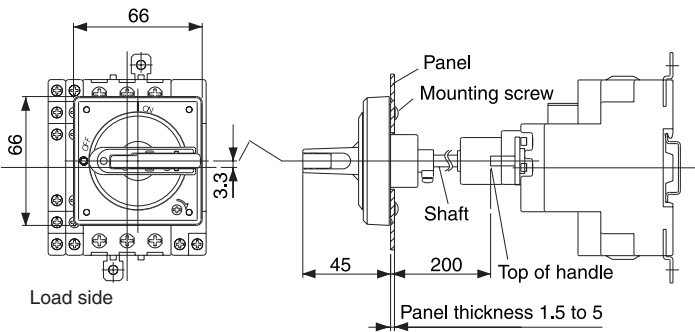

A	Type	Applicable frame
48.5	Standard / emergency stop	GPS1*H
58.5		GPS2



Dimensional drawings

Enclosure for GPS1 - Surface mounting

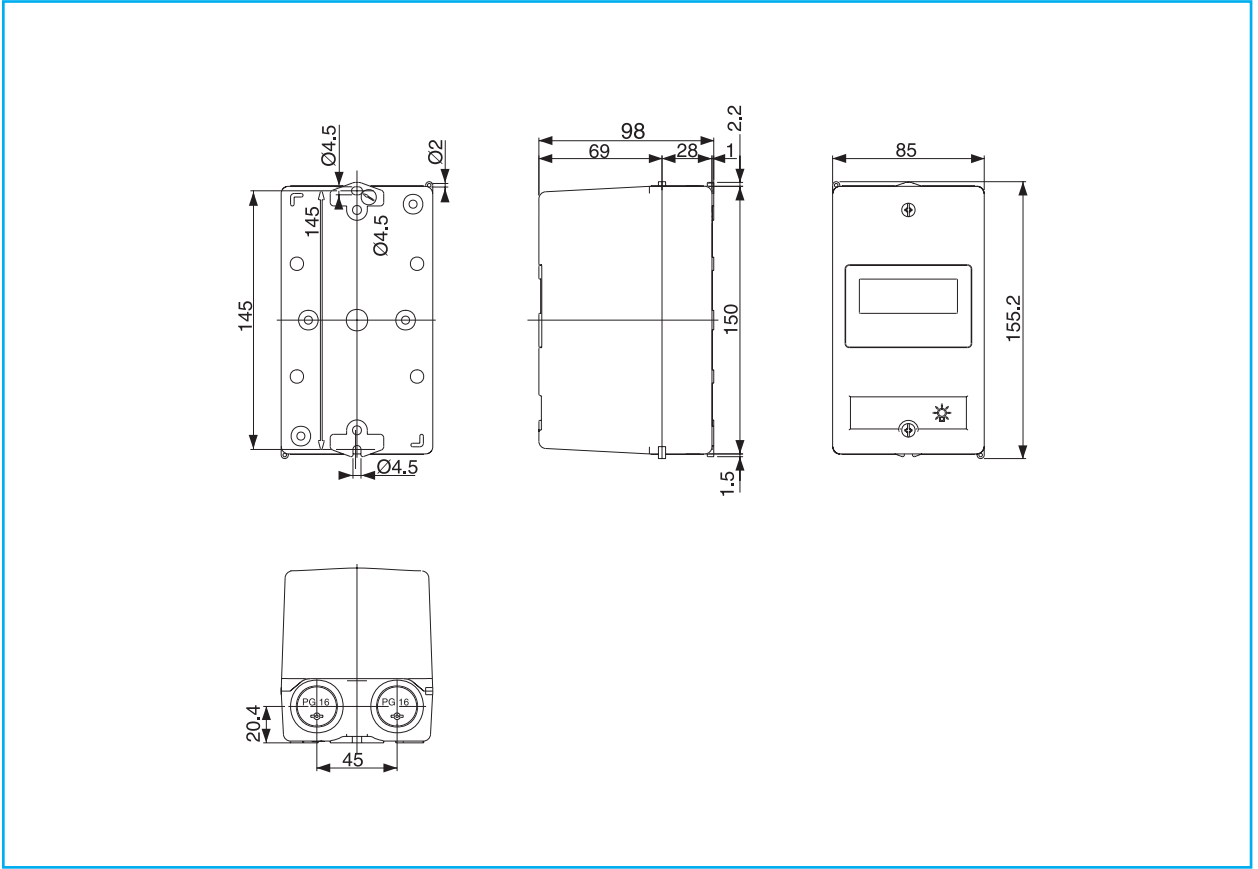

Enclosure for GPS1 - Surface mounting with padlocking device

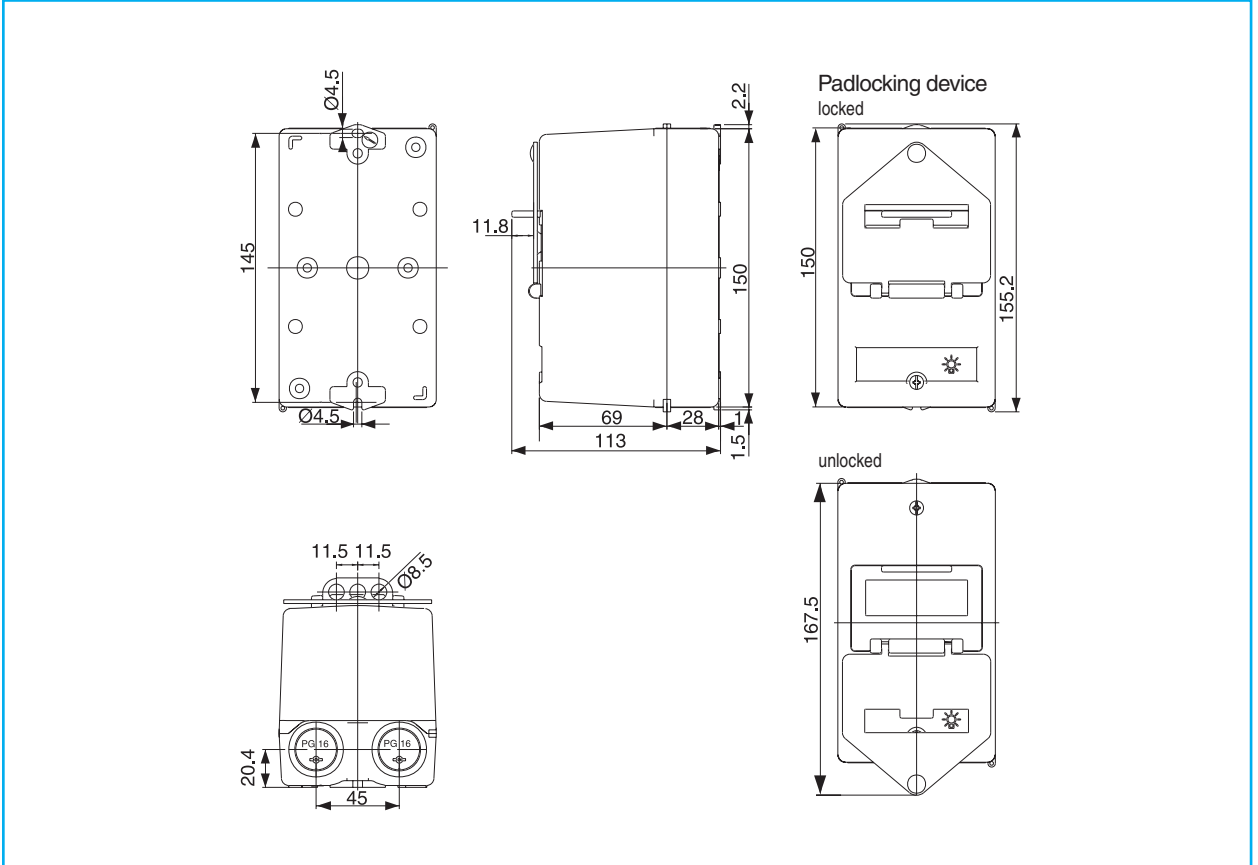

Enclosure for GPS1 - Surface mounting with emergency push-button

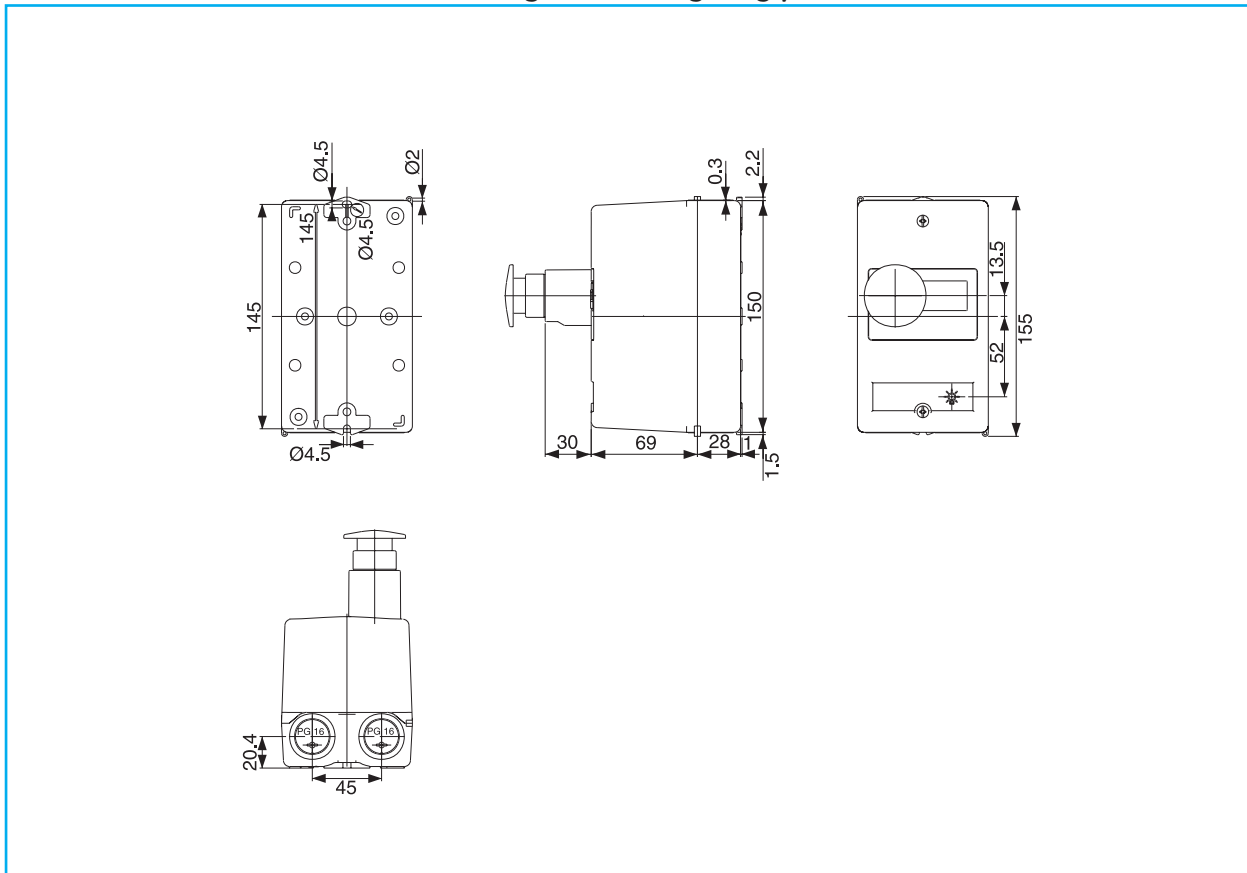

Dimensions

Intro

A

B

C

D

E

F

G

H

I

J/X



Dimensional drawings

Enclosure for GPS1 - Flush mounting

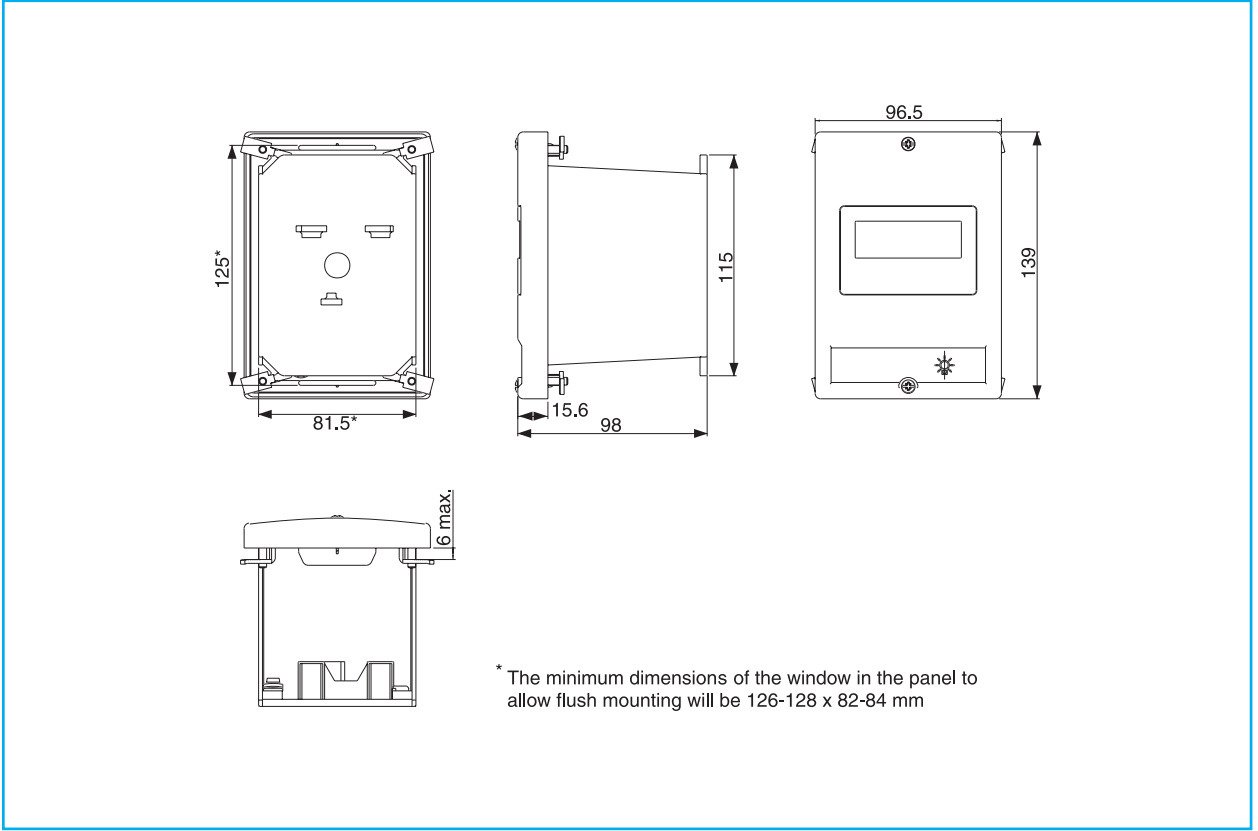

Enclosure for GPS1 - Flush mounting with padlocking device

